



Scientific Research

**Effect of Supercritical CO<sub>2</sub> and Microwave-assisted Extraction Methods on Bioactive Compounds Extraction from *Silybum marianum* Seed**

Mohadese Yousefi<sup>1</sup>, Mandana Bimakr<sup>2\*</sup>, Seyyed Mohammad Ghoreishi<sup>3</sup>, Ali Ganjloo<sup>2</sup>

1-MSc of Food Technology, Department of Food Science and Engineering, Faculty of Agriculture, University of Zanjan, Zanjan, Iran

2-Associate Professor, Department of Food Science and Engineering, Faculty of Agriculture, University of Zanjan, Zanjan, Iran

3-Professor, Department of Chemical Engineering, Faculty of Engineering, Isfahan University of Technology, Iran

**ARTICLE INFO**

**Article History:**

Received: 2023/2/9

Accepted: 2024/1/20

**Keywords:**

*Silybum marianum*,  
Bioactive compounds,  
Supercritical carbon dioxide  
extraction,  
Microwave-assisted extraction.

**DOI: 10.22034/FSCT.21.148.30.**

\*Corresponding Author E-Mail:  
[mandana.bimakr@znu.ac.ir](mailto:mandana.bimakr@znu.ac.ir)

**ABSTRACT**

In the current study, the effect of different new extraction methods including supercritical carbon dioxide extraction (SC-CO<sub>2</sub>), microwave-assisted extraction (MAE), and also conventional Soxhlet extraction (CSE) were investigated on bioactive compounds recovery from *Silybum marianum* seed. The crude extraction yield (22.40± 0.15%) was obtained using CSE, while the efficiency of SC-CO<sub>2</sub> and MAE were about 89 and 50% of those obtained using CSE. The highest free radical scavenging activity in terms of DPPH and HO radicals was obtained in an extract obtained using SC-CO<sub>2</sub>. From the TPC analysis, the highest and lowest value was determined in extracts obtained using SC-CO<sub>2</sub> (102.93± 0.14 mg GAE/g) and CSE (14.50± 0.18 mg GAE/g), respectively. Fatty acid composition was analyzed using Gas Chromatography–Mass Spectrometry. Linoleic and oleic acids were determined as the main fatty acids. Finally, it can be concluded that *S. marianum* seed is a potential source of bioactive compounds and new extraction techniques of SC-CO<sub>2</sub> and MAE could be suggested as promising methods to substitute conventional method for successful recovery of bioactive compounds.

## 1. Introduction

Based on the studies, the death statistics due to various types of cancer are always increasing due to various reasons such as environmental pollution, improper nutrition, life with stress and lack of attention to proper physical activities. Considering that plants are a source of natural antioxidant compounds, research on the production of plant extracts for application in the pharmaceutical, food, health and cosmetic industries is attracting researcher's interest [1].

Milk thistle with the scientific name of *Silybum marianum* belongs to the Asteraceae family, which grows as a medicinal plant in different parts of Iran. Milk thistle or Maritigal is considered as one of the medicinal plants of traditional European medicine. In the fourth century BC, this plant was used to treat liver, spleen and bladder stones.

The uses of this plant as a food are limited and its main importance is due to its wide medicinal application. However, in some regions of the world, raw green leaves and young stems of this plant are consumed in salads or cooked. Also, its dried leaves are consumed for preparing an herbal tea. Therefore, the cultivation of this plant as a valuable medicinal product for recovery of its effective bioactive compounds has been considered in recent years [2].

This plant contains valuable bioactive compounds such as phenols. Extraction is an important step to obtain bioactive compounds from plant sources, and since the quantitative and qualitative performance of the obtained compounds is influenced by various factors, including the extraction method, therefore, the study of extraction methods of bioactive compounds from plant sources is very important [1]. The conventional Soxhlet method (CSE) is a standard and reference method for evaluating the performance of other extraction methods, which is still used [1, 3]. In recent years, supercritical fluid extraction (SFE) has been considered as a promising alternative to conventional technologies in the separation of various high-value compounds from natural resources [3, 4]. This finding is due to the fact that SFE is usually performed at low temperatures, with a short extraction time and a small amount of solvent compared to other extraction methods [5, 6]. In addition, the solubility power of the supercritical fluid can be

controlled by changing the pressure and/or temperature. Several compounds have been selected as SFE solvents such as hexane, pentane, butane, nitrogen monoxide, sulfur hexafluoride and hydrocarbons. However, carbon dioxide has received more attention among the other solvents due to its safety, low-cost and availability [7, 8].

In addition, compounds extracted using supercritical carbon dioxide (SC-CO<sub>2</sub>) are generally recognized as safe (GRAS) for use in food [9]. So far, this technology has been used in several studies to recover bioactive compounds, depending on the process conditions, the type of raw material and also the target composition, different results have been obtained regarding the effectiveness of this method on quantitative and qualitative extraction [4, 10, 11]. Microwave-assisted solvent extraction (MAE) is another new and desirable method for extraction of bioactive compounds from plant sources. Among the new methods, this extraction method is one of the best extraction methods due to its appropriate recovery efficiency, compatibility with the environment, low cost, reduction of recovery time, and ease of use on a large or small scale. In several studies, this method has been used to extract bioactive compounds [12-15]. Also, in a comprehensive study, Chan et al. [16] have reviewed the research conducted on the application of this method to extract different compounds from different sources. In a study, Magdalena et al. [17] investigated the effect of the MAE method and compared it with the traditional method on the extraction of bioactive compounds from milk thistle seeds. It is necessary to explain that the impact of the extraction process depends on the independent variables and might have a significant effect on the process improvement. Considering that the milk thistle plant has a high medicinal value and also the MAE and SC-CO<sub>2</sub> methods are promising extraction methods, the aim of this study was to investigate the effect of the mentioned methods on the recovery of valuable compounds from this plant. Also, this study can be considered as a database for the industrialization of the extraction process. In addition, to achieve more comprehensive study, the results were compared with those obtained from conventional Soxhlet method.

## 2- Materials and Methods

### 2-1- Materials

Milk thistle seeds were purchased from the local market located in Isfahan, Iran. After cleaning, the seeds were ground by a laboratory grinding machine. After determining the particle size, the samples were kept in a freezer with a temperature of -18 °C for further analysis.

### 2-2- Conventional Soxhlet Extraction (CSE)

To perform CSE a certain amount of the sample and hydroethanolic solvent (80% V/V) were prepared with the ratio of 1:20 (W/V) and placed in the Soxhlet apparatus.

### 2-3- Supercritical Carbon Dioxide (SC-CO<sub>2</sub>) Extraction

To perform the process of supercritical carbon dioxide (SC-CO<sub>2</sub>) extraction, a certain amount (3 grams) of the prepared sample was placed in a special extraction chamber. In this extraction

method, the back pressure regulating valve was set at a certain pressure and carbon dioxide as a solvent was prepared by the pump for extraction. The temperature and pressure of the process were 55 °C and 16 Mpa, respectively. The selection of levels is based on preliminary tests. The schematic design of this device is presented in Figure 1. This device includes a tank containing carbon dioxide gas, a molecular sieve, a circulation cooler, a high-pressure pump for carbon dioxide, an inlet valve, an extraction column, a back pressure regulating valve, and a sample collection container. After completing the extraction process for 40 minutes, the obtained extract was placed in a rotary evaporator under vacuum at a temperature of 40 °C to remove the solvent, and then it was placed in an oven for 1 hour. The dried extract was used for the further analysis.

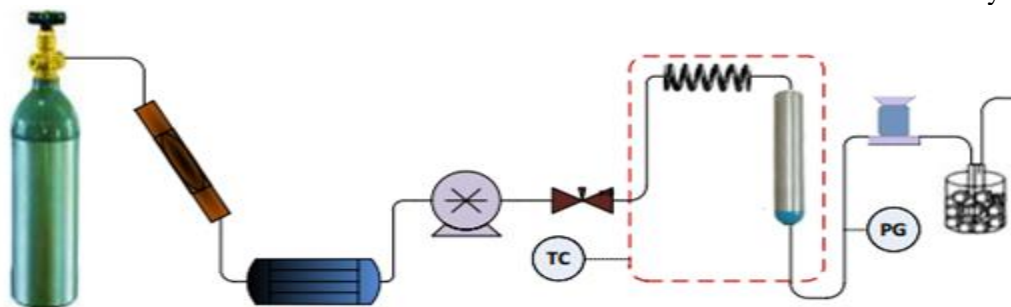

Fig 1. Schematic diagram of supercritical fluid extractor [33, 38]

### 2-4- Microwave Assisted Extraction (MAE)

To perform microwave-assisted extraction (MAE), a certain amount of the sample and hydroethanolic solvent (80% v/v) were prepared in the ratio of 1:20 (w/v) and placed in the microwave extractor.

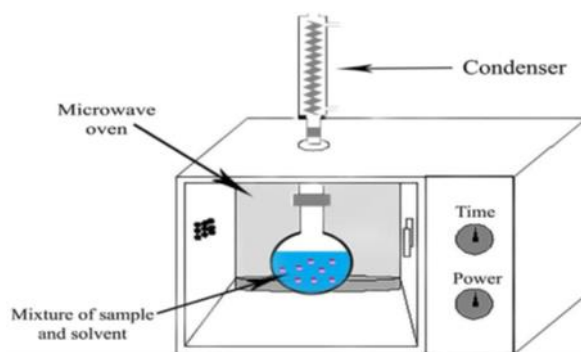

Fig 2. Schematic diagram of microwave assisted extractor

### 2-5- Qualitative and quantitative analysis of extracted bioactive compounds

#### 2-5-1- Determination of extraction yield

The extraction yield was determined using equation (1).

Equation (1)

$$\text{Extraction yield (\%)} = \left(\frac{m_2}{m_1}\right) \times 100$$

where  $m_1$  is the weight of the sample before the extraction process (g),  $m_2$ : weight of the obtained extract (g).

### 2-5-2- Measurement of DPPH free radical scavenging activity

The amount of antiradical activity of the bioactive compounds obtained from the milk thistle seeds was measured according to the method of Poodi et al. [18]. Firstly, 0.1 mL of the extract diluted in ethanol (respecting the concentration of 0.1 g/mL) was added to 2.9 mL of ethanolic DPPH solution. The sample was mixed for 30 s. After 30 min of storage in a dark place, the absorbance at a wavelength of 517 nm was read by a visible-ultraviolet spectrometer (SPECORD 250, Germany), and finally, the percentage inhibition of DPPH free radicals by the bioactive compounds was calculated using Equation (2):

Equation (2):

$$\text{DPPH}^{\circ}sc (\%) = \frac{A_b - A_s}{A_b} \times 100$$

where,  $A_b$  is the absorption of the control and  $A_s$  is the absorption of the sample.

### 2-5-3- Measurement of hydroxyl free radical scavenging activity

To evaluate the inhibition of hydroxyl free radicals by the bioactive compounds extracted from the milk thistle seeds, firstly, 1 mL of the prepared sample (diluted with ethanol with a ratio of 1:10 w/v) was mixed with 1 mL of ferrous sulfate, 1 mL of salicylic acid and 1 mL of hydrogen peroxide. Then, it was placed in a water bath at 37 °C for 1 h, and the absorbance at a wavelength of 520 nm was determined by a visible-ultraviolet spectrometer (SPECORD 250, Germany), and the amount of inhibition of hydroxyl free radicals was calculated from equation 3 [19].

Equation (3):

$$\%HOSC = \frac{A_b - A_s}{A_b} \times 100$$

where,  $A_b$  is the absorption of the control and  $A_s$  is the absorption of the sample.

### 2-5-4- Measurement of total phenolic content

The total phenolic content of the extracts was measured using Folin-Cicalto method. For this purpose, 100  $\mu$ L of the extract diluted with ethanol (respecting the concentration of 0.1 g/mL) and 0.75 mL of Folin-Cicalto reagent (diluted with distilled water with a ratio of 1:10 w/v) were mixed and kept for 5 min at room

temperature. Then, 0.75 mL of sodium carbonate solution (6% w/v) was added to the mixture and stirred slowly. After keeping for 90 minutes at room temperature, the amount of absorbance at 765 nm wavelength was read by a visible-ultraviolet spectrometer (SPECORD 250, Germany) [20].

### 2-5-5- Preparation of fatty acid methyl esterification

For this purpose, the samples were first brought to a temperature of 50-55 °C and then homogenized using a vortex machine. 100  $\mu$ L of the sample was mixed with 1 mL of hexane. Then, 10  $\mu$ L of sodium methoxide was added to the samples. The sample was taken from the upper transparent layer for injection into a gas chromatography device equipped with a mass spectroscope (GC-MS) [21].

### 2-5-6- Analysis using GC-MS

fatty acids analysis was done according to the method of Bimakr et al. [21] with some minor changes. In order to determine the methyl ester of fatty acids, GC-MS equipped with a capillary column with a length of 60 m and a diameter of 0.25 mm with a film thickness of 0.25  $\mu$ m was used. The initial temperature of the oven was 80 °C, which reached 200 °C by programming the temperature with a temperature increase of 15 °C per minute and was kept at this temperature for 5 minutes. Then, with an increase of 30 °C, it reached a temperature of 230 °C and was kept at this temperature for 10 minutes. The injection valve temperature was set to 220 °C. Helium gas with a flow rate of 0.7 mL/min was used as carrier gas.

### 2-6- Data Analysis

Experimental data obtained from SC-CO<sub>2</sub>, MAE and CSE extraction methods was analyzed by analysis of variance using generalized linear model. The comparison of averages was performed by Tukey test method at 95% confidence level using Minitab software (V. 14, Minitab Inc. State College, PA, USA) Excel software was used to draw the graphs. All experiments were performed considering at least three repetitions and data were reported as mean  $\pm$  standard deviation.

## 3-Results and Discussion

### 3-1- Evaluation the effect of extraction methods on the quantity of extracts

Quantitative extraction yield of bioactive compounds obtained from the milk thistle seeds was investigated under the influence of different extraction methods including CSE, MAE and SC-CO<sub>2</sub> and the results are shown in

Figure 3. The results show the different ability of the studied methods to isolate bioactive compounds from the seeds. The highest value of quantitative recovery of bioactive compounds was obtained by Soxhlet method ( $22.40 \pm 0.15\%$ ). The efficiency of SC-CO<sub>2</sub> and MAE methods was about 89 and 50% of the Soxhlet method, respectively. In a study, Hasanlou et al. [22] reported the quantitative yield of bioactive compounds extracted from thistle seeds using the heating method was equal to 25%. The difference between their quantitative results and the results obtained in the present study can be caused by the different variety, weather conditions, degree of ripening and also the type of extraction method [23]. It is important to note that the increase in quantitative yield in the Soxhlet method can be caused by the extraction of unwanted and non-phenolic compounds, which will cause a slight increase in the final extract. Similar results have been reported by Bimakr et al. [7]. In a study, they investigated the effect of supercritical carbon dioxide and Soxhlet methods on the extraction of phenolic compounds from *Mentha spicata* leaves. The higher value of crude yield was obtained using the Soxhlet method, which was due to the extraction of non-phenolic and unwanted compounds. One of the most important factors is the extraction time which is considered as 40 min, 12 min, and 6 hours for SC-CO<sub>2</sub>, MAE, and CSE extraction methods, respectively. The longer process time accompanied with the high temperature can ultimately lead to an increase in the quantitative performance of the process. In general, during the extraction process, the solvent diffuses into the plant material and dissolves compounds with similar polarity. The biological activities of the extracted compounds depend on the type and amount of the extracted compounds and the ratio of the extracted materials [1, 3]. The target compounds are generally located in the intercellular space in a complex structure consisting of cells, intercellular space and intracellular pores. The cell wall is one of the main obstacles to the extraction of these compounds from the structure of plants. Therefore, increasing the permeability of the cell wall plays an important role in increasing the efficiency and speed of extraction. In the traditional Soxhlet method, the contact of the sample for a long time with high temperature causes the target compounds to be released from the plant cell to the surrounding

environment [25]. In the MAE method, when the sample is exposed to microwaves, the main mechanisms for heat generation by microwaves are dipole rotation and ion conduction. Ionic conductivity is caused by the movement of ions in response to an electric field. The electric field transfers kinetic energy to the ions. Due to the collision of ions with each other, kinetic energy is converted into heat. In dipole rotation, when polar molecules are exposed to microwaves, they try to change their orientation in the direction of the field, and this causes friction between molecules and heat generation. Water is the most important polar molecule in biological materials, whose content has a great effect on the amount of heating by microwaves [26, 27]. In microwave recovery, the purpose of heating dry plant material is to heat the remaining water in the plant cells. Heating in this method causes evaporation of the small amount of moisture in the cell of dry plant material and puts a lot of pressure on the cell wall. The cell wall weakens and breaks due to this pressure. In this way, the exit of bioactive compounds from the damaged cell occurs and helps to increase the recovery efficiency of the target compounds. Also, the use of solvent can cause a slight increase in extraction performance. In addition, increasing the temperature causes faster penetration of the solvent into the cell wall of the plant matrix and higher recovery efficiency [15, 28]. Regarding the effect of the SC-CO<sub>2</sub> method, it can be stated that any material with pressure and temperature higher than the critical point is called a supercritical fluid. In this case, gas and liquid phases are not different from each other. Supercritical fluids, such as supercritical carbon dioxide, behave like liquids in terms of solubility, and behave like gases in terms of transfer and penetration properties, as a result, supercritical fluids easily penetrate into the porous solids. Selective extraction and complete separation of solvent and solute are other advantages of supercritical fluids. On the other hand, the surface tension of these fluids is close to zero, and for this reason, they have the ability to penetrate into structures with narrow channels in the micro and nano scale [3, 4]. According to the results, the quantitative performance of the obtained extracts is influenced by different extraction methods, which is consistent with the results expressed by Rezazadeh et al. [29]. In another study, Mousavi et al [30] investigated the effect of

different methods on the extraction of bioactive compounds from feijoa leaves. They also reported that the highest quantitative yield

values can be achieved using the Soxhlet method and lower values can be achieved using supercritical carbon dioxide.

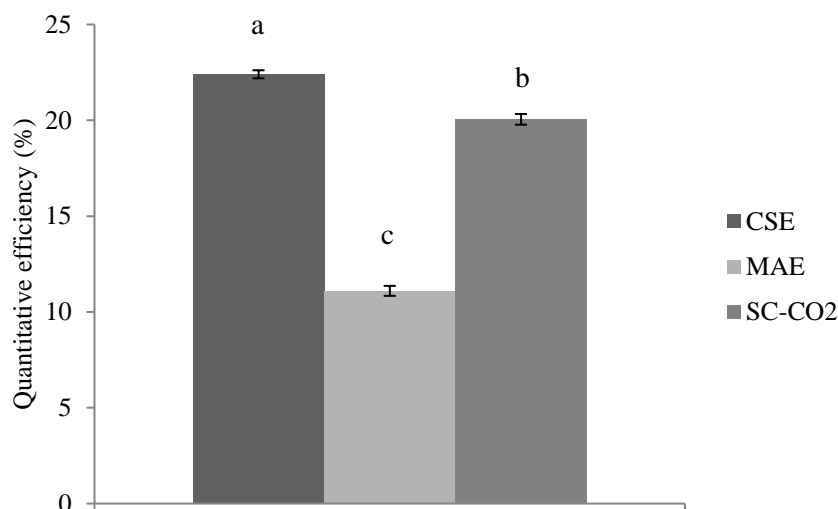

**Fig 3.** Effect of different extraction techniques of MAE, SC-CO<sub>2</sub> and CSE on quantitative efficiency

### 3-2- Evaluation the effect of extraction methods on the total phenolic content

Bioactive phenolic compounds are widely found in various plant sources. These bioactive compounds, which are part of secondary metabolites, inhibit or delay the oxidation reaction by neutralizing free radicals [31]. In the present study, the total phenolic content of the bioactive compounds was investigated under the influence of different extraction methods studied, including Soxhlet, MAE and SC-CO<sub>2</sub>, and the results are shown in Figure 4. As can be seen, the lowest and the highest total phenolic content of extracts are related to CSE and SC-CO<sub>2</sub> methods, respectively. The results of MAE technology were significantly higher than the values of CSE method ( $p < 0.05$ ). These results can indicate the thermal degradation of target compounds due to Soxhlet extraction. Phenolic compounds are thermally unstable bioactive compounds that can be destroyed by applying high temperatures for a long time [7]. In a study, Ahmadi et al [32] reported the amount of total phenolic compounds obtained from milk thistle seed as 29 mg GAE/g. The difference between the results of the present study and their findings can be caused by the difference in the extraction methods and the physiological characteristics of the seed [23]. Regarding the effectiveness of the MAE method, in a study by Radojković et. al [33], they optimized the MAE technology to recover

phenolic compounds from *Morus nigra* leaves. They reported that MAE technology can be used to recover phenolic compounds (19.70 mg GAE/g) from the studied plant leaves. They attributed their results to extensive and severe destruction of cell structure caused by microwave radiation [33]. In a study, Mousavi et al [30] compared the effect of SC-CO<sub>2</sub> and traditional methods on the content of phenolic bioactive compounds obtained from the leaves of the feijoa plant. They also mentioned that higher amounts of phenolic compounds can be extracted using the SC-CO<sub>2</sub> method compared to the traditional method. They stated that this increase is due to extensive cell destruction and proper solubility of the target compounds in the supercritical fluid.



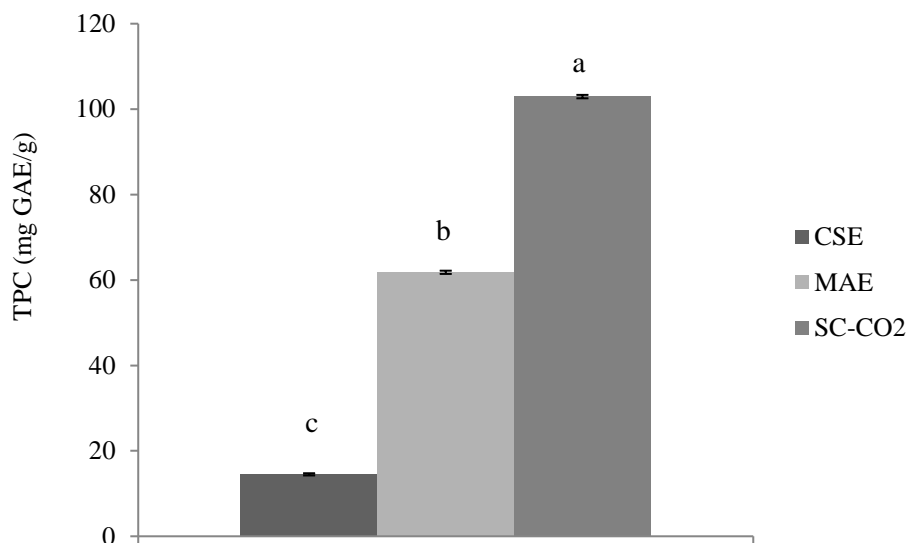

**Fig 4.** Effect of different extraction techniques of MAE, SC-CO<sub>2</sub> and CSE on TPC.

### 3-3- Evaluation the effect of extraction methods on the antiradical activity

Free radicals are intermediate compounds that are created during the body's natural metabolic process and are effectively neutralized by the body's antioxidant system. In addition, free radicals are caused by stress, disease, drugs and pollution and cause damage to cell structures, DNA, proteins and lipids, and also play an important role in causing cancer, cardiovascular diseases, arteriosclerosis and neurological disorders [34 , 35]. Since any imbalance in the neutralization process of free radicals causes oxidative stress, therefore, controlling this process is of particular importance. Among the methods used to control oxidation, the use of antioxidants is the most effective, appropriate and economical method [36]. Therefore, in recent years, the tendency of researchers to identify natural antioxidant compounds and replace them instead of synthetic antioxidant compounds is increasing [28]. In the present study, the antiradical capacity of the bioactive compounds obtained from the seeds of the milk thistle plant was investigated under the influence of different recovery methods including CSE, MAE and SC-CO<sub>2</sub> using DPPH and HO free radical inhibition methods, and the results are shown in Figure 5. Measuring the DPPH free radicals scavenging activity is one of the simple, fast and cheap methods that is widely used [35]. According to the obtained results, the highest amount of anti-radical activity of bioactive compounds recovered

from milk thistle seed measured by DPPH method, corresponding to SC-CO<sub>2</sub> methods (79.65±0.23%), MAE (58.04±0.18), and CSE (14.50±0.20 percent) respectively. A similar trend was observed for the inhibition of HO free radicals. In this study, as mentioned earlier, the use of MAE and SC-CO<sub>2</sub> technologies led to the extraction of compounds with higher anti-radical capacity compared to the traditional Soxhlet method. This result can be caused by the destruction of the cell structure and as a result of better penetration of the solvent and ultimately more efficient transfer of the target compounds with anti-radical activity from the cell structure to the surrounding environment. A fluid becomes supercritical when the temperature and pressure are above the critical point. In supercritical conditions, fluid properties mediate between gases and liquids, thus facilitating the extraction of compounds [37]. In addition, the thermal degradation of bioactive compounds due to the application of high temperature over a long period of time has led to a decrease in the antiradical capacity of bioactive compounds obtained using the Soxhlet method. Mousavi et al. [38] in a study investigated the anti-radical capacity of compounds obtained from feijoa leaves using SC-CO<sub>2</sub> technology. They reported the %DPPH<sub>sc</sub> and %HO<sub>sc</sub> values as 85.16 and 75.66%, respectively, which were significantly higher than the antiradical activity of compounds recovered using the traditional method ( $p < 0.05$ ) [38]. In another study, similar

results regarding the effect of MAE and traditional methods on the extraction of bioactive compounds from sea buckthorn seeds have been reported by Magdalena et al. [17]. According to the results presented in Figure 6, there is a clear relation ( $R > 0.9736$ ) between the results of the amount of total phenolic compounds and the antiradical activity of the compounds obtained from the seeds under the influence of different recovery methods. Similar results regarding the correlation between the antiradical capacity and the content of total phenolic compounds have been reported in other studies [39]. According to the present results, it can be stated that the seeds of this plant have a significant anti-radical capacity, which can be considered as a rich and valuable resource for future applications in various food, pharmaceutical and cosmetic industries. Also,

the new MAE and SC-CO<sub>2</sub> methods are efficient methods to recover valuable compounds from this seed. In other studies, MAE and SC-CO<sub>2</sub> methods have been successfully used to extract bioactive compounds [40, 41].

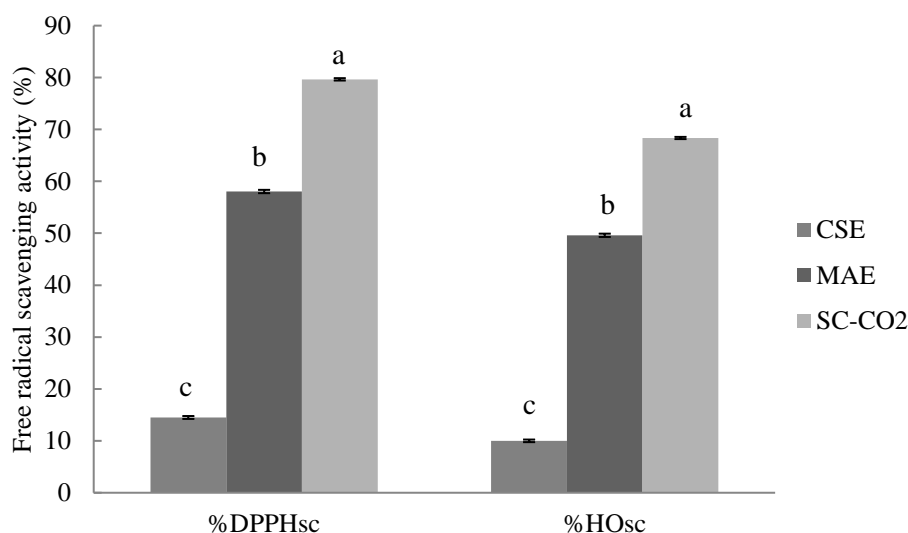

**Fig 5.** Effect of different extraction techniques of MAE, SC-CO<sub>2</sub> and CSE on free radical scavenging activity.



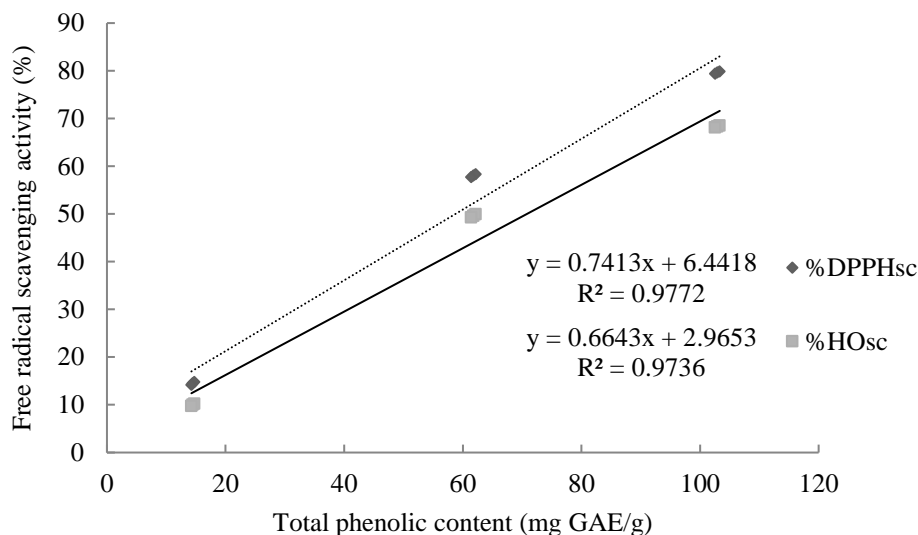

**Fig 6.** Correlation between total phenolic content and free radical scavenging activity

### 3-4- Evaluation the effect of extraction methods on the fatty acid profile

Fatty acids profile of the bioactive compounds obtained from the milk thistle seeds obtained under the influence of different recovery methods were investigated using GC-MS and the results are given in Table 1. Based on the obtained results, linoleic acid (18:2 n-6) and oleic acid (18:1 n-9) were identified as the predominant fatty acids. In other words, the compounds obtained from this seed are rich in unsaturated fatty acids. In recent years, the health-giving effects of this group of fatty acids on human health have been shown in various studies [42, 43]. Therefore, finding rich sources of these compounds is very important. The seeds of this plant are one of the rich sources of these valuable compounds. In a study, Hassanlou et al. [22] introduced linoleic acid as the predominant fatty acid present in the milk thistle seeds. A slight difference between their quantitative results and the results obtained in the present study was observed. The differences in the data can be caused by differences in the variety and climatic conditions [23]. Based on the present results, the use of different recovery methods did not have a significant effect on the composition of fatty acids. In a study, Samaram et al. [44] investigated the effect of extraction methods on the fatty acid profile of bioactive compounds recovered from papaya seeds. Oleic acid (74.00-70.50%) was determined as the major fatty acid in the seed and also, they reported that the type of recovery method has no significant effect on the fatty acid composition of the seed [44]. Similar results were also reported by Sicaire et al. [45]

regarding the effect of the extraction method on the fatty acids recovered from rapeseed. In addition, the results of the analysis of the fatty acid profile of the studied samples were compared with the available results for sunflower seeds and soybeans (Table 1). As shown, sunflower seeds and soybeans are rich in the unsaturated fatty acid linoleic acid, and milk thistle seeds are also rich in this valuable compound vital for human health. Finally, MAE and SC-CO<sub>2</sub> technologies can be considered as promising alternatives to conventional methods such as CSE due to their non-destructive effect on fatty acid composition, process management to achieve a product rich in valuable bioactive compounds.

**Table 1:** Fatty acid composition of bioactive compounds obtained using different extraction techniques and its comparison with soybean and sunflower

Fatty acid (%)		Plant					
		Soybean*	Sunflower*	<i>S. marianum</i>			
				Reflux*	Soxhlet	MAE	SC-CO <sub>2</sub>
		[22]	[22]	[22]	[22]	[22]	[22]
Palmitic acid	16:0	11.23±0.20	6.50±0.00	8.25±0.20	8.04 <sup>a</sup> ±0.12	7.96 <sup>a</sup> ±0.15	8.00 <sup>a</sup> ±0.15
Palmeotic acid	16:1	0.05±0.20	0.04±0.30	0.07±0.10	-	-	-
Stearic acid	18:0	4.70±0.20	4.07±0.20	6.67±0.10	6.72 <sup>a</sup> ±0.11	6.69 <sup>a</sup> ±0.13	6.78 <sup>a</sup> ±0.12
Oleic acid	18:1	22.52±0.10	31.27±0.0	31.58±0.40	31.62 <sup>a</sup> ±0.15	31.54 <sup>a</sup> ±0.11	31.58 <sup>a</sup> ±0.14
Isomer oleic acid	Iso-C18:1	1.50±0.30	0.75±0.20	0.53±0.20	0.58 <sup>a</sup> ±0.15	0.60 <sup>a</sup> ±0.10	0.61 <sup>a</sup> ±0.13
Linoleic acid	18:2	52.07±0.20	56.04±0.40	45.36±0.20	45.20 <sup>a</sup> ±0.13	45.14 <sup>a</sup> ±0.16	45.22 <sup>a</sup> ±0.12
Linolenic acid	18:3	6.89±0.50	0.27±0.00	0.87±0.30	0.94 <sup>a</sup> ±0.11	0.87 <sup>a</sup> ±0.13	0.92 <sup>a</sup> ±0.11
Arashidic acid	20:0	0.43±0.20	0.31±0.30	4.11±0.20	3.80 <sup>a</sup> ±0.14	3.75 <sup>a</sup> ±0.17	3.81 <sup>a</sup> ±0.12
Eicozantoic acid	20:1	0.20±0.20	0.19±0.40	0.088±0.00	-	-	-
Behenic acid	22:0	0.47±0.00	0.75±0.10	2.6±0.00	2.65 <sup>a</sup> ±0.10	2.60 <sup>a</sup> ±0.10	2.66 <sup>a</sup> ±0.00

\*Same lower letters in each row represents not significant difference ( $p>0.05$ ).

#### 4-Conclusion

In the present study, the application of new methods of SC-CO<sub>2</sub> and MAE led to a significant increase ( $p < 0.05$ ) in the anti-radical properties and total phenolic content of the bioactive compounds recovered from the milk thistle seeds compared to the traditional Soxhlet method. However, the efficiency of these recovery methods was determined to be about 89 and 50% of the Soxhlet method, respectively. Therefore, the use of new methods increased the anti-radical properties and total phenol content of the recovered compounds compared to the traditional Soxhlet method. Furthermore, according to the results obtained from the GC-MS regarding the identification of the fatty acid profile, it can be stated that the type of extraction method does not have a negative effect on the fatty acid composition.

#### 5-References

- [1] Azmir, J., et al. 2013. Techniques for extraction of bioactive compounds from plant materials: A review. *Journal of Food Engineering*. 699: 426-436.
- [2] Qavami, N., et al. 2013. A review on pharmacological, cultivation and biotechnology aspects of Milk Thistle (*Silybum marianum* (L.) Gaertn.). *Journal of Medicinal Plants*. 12: 19- 37.
- [3] Bimakr, M., et al. 2012. Optimization of supercritical carbon dioxide extraction of bioactive flavonoid compounds from spearmint (*Mentha spicata* L.) leaves by using response surface methodology. *Food and Bioprocess Technology*. 5: 912-920.
- [4] Bimakr, M., et al. 2019. Modified supercritical carbon dioxide extraction of biologically active compounds from *Feijoa sellowiana* leaves. *International Journal of Food Engineering*. 20180342.
- [5] Bimakr, M., et al. 2013. Supercritical carbon dioxide extraction of seed oil from winter melon (*Benincasa hispida*) and its antioxidant activity and fatty acid composition. *Molecules*. 18: 997-1014.
- [6] Bashipour, F. and Ghoreishi, S.M. 2012. Experimental optimization of supercritical extraction of  $\beta$ -carotene from *Aloe barbadensis* Miller via genetic algorithm. *The Journal of Supercritical Fluids*. 72: 312-319.
- [7] Bimakr, M., et al. 2011. Comparison of different extraction methods for the extraction of major bioactive flavonoid compounds from spearmint (*Mentha spicata* L.) leaves. *Food and Bioproducts Processing*. 89: 67-72.
- [8] Liza, M.S., et al. (2010). Supercritical carbon dioxide extraction of bioactive flavonoid from *Strobilanthes crispus* (Pecah Kaca). *Food and Bioproducts Processing*. 88: 319-326.
- [9] Gerard, D. and May, P. 2002. Herb and spice carbon dioxide extracts-versatile, safe ingredients for premium food and health food. *Food Technology*. 2: 1-5.
- [10] Ghoreishi, S., Hedayati, A. and Kordnejad, M. 2016. Micronization of chitosan via rapid expansion of supercritical solution. *Journal of Supercritical Fluids*. 111:162-70.
- [11] Argun, M.E. et al. 2022. Recovery of valuable compounds from orange processing wastes using supercritical carbon dioxide extraction. *Journal of Cleaner Production*. 375: 134169.
- [12] Sarfarazi, M., et al., (2020). Evaluation of microwave-assisted extraction technology for separation of bioactive components of saffron (*Crocus sativus* L.). *Industrial Crops and Products*. 145: 111978.
- [13] Mellinas, A., Jiménez, A. and Garrigós, M. 2020. Optimization of microwave-assisted extraction of cocoa bean shell waste and evaluation of its antioxidant, physicochemical and functional properties. *LWT*. 127: 109361.
- [14] Araújo, R.G., et al. (2020). Process optimization of microwave-assisted extraction of bioactive molecules from avocado seeds. *Industrial Crops and Products*. 154: 112623.
- [15] Pengdee, C., Sritularak, B. and Putalun, W. 2020. Optimization of microwave-assisted extraction of phenolic compounds in *Dendrobium formosum* Roxb. ex Lindl. and glucose uptake activity. *South African Journal of Botany*. 132: 423-431.
- [16] Chan, C.H., et al. 2011. Microwave-assisted extractions of active ingredients from plants. *Journal of Chromatography A*. 16:6213-6225.
- [17] Magdalena, M., Lukasiewicz, M. and Jakubowski, P. 2015. Microwave-assisted extraction of bioactive compounds from seeds of milk thistle, black cumin and coriander. b005. 10.3390/ecsoc-19-b005.
- [18] Poodi, Y., et al. 2018. Intensification of bioactive compounds extraction from *Feijoa sellowiana* leaves using ultrasonic waves. *Food Bioproducts Processing*. 108: 37-50.
- [19] Ma, J.S., et al. 2020. Extraction, characterization and antioxidant activity of

polysaccharide from *Pouteria campechiana* seed. Carbohydrate Polymers. 229: 115409.

[20] Ismail, A., Marjan, Z.M. and Foong, C.W. 2004. Total antioxidant activity and phenolic content in selected vegetables. Food chemistry. 87: 581-586.

[21] Bimakr, M., et al. 2016. Characterization of valuable compounds from winter melon (*Benincasa hispida* (Thunb.) Cogn.) seeds using supercritical carbon dioxide extraction combined with pressure swing technique. Food and Bioprocess Technology. 9: 396-406.

[22] Hasanloo, T., et al. (2008). Determination of tocopherols and fatty acids in seeds of *Silybum marianum* (L.) Gaerth. Journal of Medicinal Plants. 7: 69-76.

[23] Frum, A. 2017. HPLC determination of polyphenols from L. Flowers. Acta Universitatis Cibiniensis. Series E: Food Technology. 2:197-101.

[24] Spinei, M. and Oroian ,M. 2023. Structural, functional and physicochemical properties of pectin from grape pomace as affected by different extraction technique. International Journal of Biological Macromolecule. 224: 739-753.

[25] Kant, R. and Kumar ,A. 2022. Review on essential oil extraction from aromatic and medicinal plants: Techniques, performance and economic analysis. Sustainable Chemistry and Pharmacy. 30: 2352-5541.

[26] Huschek, G., et al. 2022. Characterization and optimization of microwave-assisted extraction of B-phycoerythrin from *Porphyridium purpureum* using response surface methodology and Doehlert design. Bioresource Technology Reports. 19: 101212.

[27] Boyapati, T., Rana, S.S. and Ghosh, P. 2022. Microwave-assisted extraction of dragon fruit seed oil: Fatty acid profile and functional properties. Journal of the Saudi Society of Agricultural Sciences. ISSN 1658-077X, In press.

[28] Roshani Neshat, R., Bimakr, M. and Ganjloo, A. 2022. Effects of Zedo gum edible coating enriched with microwave-agitated bed extracted bioactive compounds from lemon verbena leaves on oxidative stability of *Oncorhynchus mykiss*. Food Measurements and Characterization. 16: 4388-4401.

[29] Rezazadeh, B., et al. 2008. Comparison of super critical fluid extraction and hydrodistillation methods on Lavander's essential oil composition and yield. Journal of Medicinal Plants. 7: 63-68.

[30] Mousavi, M., et al. 2018. Supercritical carbon dioxide extraction of bioactive compounds from feijoa (*Feijoa sellowiana*) leaves. Nutrition and Food Sciences Research. 5: 15-23.

[31] Garcia-Salas, P., et al. 2010. Phenolic compound extraction systems for fruit and vegetable samples. Molecules. 15: 8813-8826.

[32] Mhamdi, B., et al. 2016. Fatty acids, essential oil and phenolics composition of *Silybum marianum* seeds and their antioxidant activities. Pakistan Journal of Pharmaceutical Sciences. 29: 951-959.

[33] Radojković, M., et al. 2017. Microwave-assisted extraction of phenolic compounds from *Morus nigra* leaves: optimization and characterization of the antioxidant activity and phenolic composition. Journal of Chemical Technology and Biotechnology. 93: 85-93.

[34] Lobo, V., et al. 2010. Free radicals, antioxidants and functional foods: Impact on human health. Pharmacognosy Reviews. 4: 118-126.

[35] Noroozi, F., et al. 2021. A short time bioactive compounds extraction from *Cucurbita pepo* seed using continuous ultrasound-assisted extraction. Journal of Food Measurement and Characterization. 15: 2135-2145.

[36] Li, A., et al. 2011. Antioxidant and immunoregulatory activity of different polysaccharide fractions from tuber of *Ophiopogon japonicus*. Carbohydrate Polymers . 86 :1273-1280.

[37] Sinemobong, O. Essien, B.Y. and Baroutian ,S. 2020. Recent advances in subcritical water and supercritical carbon dioxide extraction of bioactive compounds from plant materials. Trends in Food Science and Technology. 97: 156-169.

[38] Mousavi, M.S., et al. 2019. Modified supercritical carbon dioxide extraction of biologically active compounds from *Feijoa Sellowiana* leaves. International Journal of Food Engineering. 15: 20180342.

[39] Mojaradi, F., Bimakr, M. and Ganjloo, A. 2021. Feasibility of hydroethanolic solvent system for bioactive compounds recovery from aerial parts of *Silybum marianum* and kinetics modeling. Journal of Human Environment and Health Promotion. 7: 129-137.

[40] Kaur, S., and Ubeyitogullari, A. 2023. Extraction of phenolic compounds from rice

husk via ethanol-water-modified supercritical carbon dioxide ,*Heliyon* ,9: e14196.

[41] Cheng, M., et al. 2023. Comparison of microwave, ultrasound and ultrasound-microwave assisted solvent extraction methods on phenolic profile and antioxidant activity of extracts from jackfruit (*Artocarpus heterophyllus* Lam.) pulp, *LWT*, 173: 114395.

[42] Mao, R., et al. 2022. An efficient and sensitive method on the identification of unsaturated fatty acids in biosamples: Total lipid extract from bovine liver as a case study. *Journal of Chromatography A*. 1675: 463176.

[43] de Souza, R.J., et al. 2015. Intake of saturated and trans unsaturated fatty acids and risk of all-cause mortality, cardiovascular disease, and type 2 diabetes: systematic review and meta-analysis of observational studies. *BMJ Clinical Research*. 351: 3978.

[44] Samaram, S., et al. 2013. Ultrasound-assisted extraction (UAE) and solvent extraction of papaya seed oil: yield, fatty acid composition and triacylglycerol profile .*Molecules*. 18: 12474-12487.

[45] Sicaire, A.G., et al. 2016. Ultrasound induced green solvent extraction of oil from oleaginous seeds. *Ultrasonics Sonochemistry*. 31: 319-329.



مقاله علمی-پژوهشی

تأثیر روش‌های دی اکسید کربن فوق بحرانی و مایکروویو بر استخراج ترکیبات زیست‌فعال از دانه خارمریم

محدثه یوسفی<sup>۱</sup>، ماندانا بی مکر<sup>۲\*</sup>، سید محمد قریشی<sup>۳</sup>، علی گنجلو<sup>۲</sup>

۱- کارشناس ارشد فناوری مواد غذایی، گروه علوم و مهندسی صنایع غذایی، دانشکده کشاورزی، دانشگاه زنجان، زنجان، ایران

۲- دانشیار گروه علوم و مهندسی صنایع غذایی، دانشکده کشاورزی، دانشگاه زنجان، زنجان، ایران

۳- استاد گروه مهندسی شیمی، دانشکده مهندسی شیمی، دانشگاه صنعتی اصفهان، ایران

اطلاعات مقاله	چکیده
<b>تاریخ های مقاله :</b> تاریخ دریافت: ۱۴۰۱/۱۱/۲۰ تاریخ پذیرش: ۱۴۰۲/۱۰/۳۰	در پژوهش حاضر، تأثیر روش‌های نوین استخراج دی اکسید کربن فوق بحرانی (SC-CO <sub>2</sub> ) و حلال به کمک مایکروویو (MAE) و هم چنین روش سنتی سوکسله (CSE) بر استخراج ترکیبات زیست‌فعال از دانه گیاه دارویی خار مریم مورد مطالعه قرار گرفت. بالاترین مقدار عملکرد کمی (۲۲/۴۰±۰/۱۵ درصد) با استفاده از روش CSE به دست آمد. در حالی که، کارایی روش های SC-CO <sub>2</sub> و MAE به ترتیب در حدود ۸۹ و ۵۰ درصد روش سوکسله بود. بالاترین میزان توانایی مهار رادیکال‌های آزاد DPPH <sup>•</sup> و HO <sup>•</sup> توسط ترکیبات زیست‌فعال حاصل از روش SC-CO <sub>2</sub> مشاهده گردید. نتایج حاصل از اندازه‌گیری محتوای فنول کل نشان داد که بیشترین (۱۰۲/۹۳±۰/۱۴ میلی‌گرم معادل گالیک اسید بر گرم) و کمترین (۱۴/۵۰±۰/۱۸ میلی‌گرم معادل گالیک اسید بر گرم) مقدار به ترتیب مربوط به ترکیبات حاصل از روش‌های SC-CO <sub>2</sub> و CSE می‌باشد. پروفایل اسید چرب با استفاده از دستگاه گاز کروماتوگرافی-آشکارساز جرمی شناسایی گردید. اسیدهای چرب لینولئیک اسید و اولئیک اسید به‌عنوان اسیدهای چرب غالب شناسایی شدند. به‌صورت کلی می‌توان اذعان نمود که دانه گیاه خارمریم منبع غنی از ترکیبات زیست‌فعال می‌باشد که استفاده از تکنیک‌های نوین SC-CO <sub>2</sub> و MAE می‌تواند جایگزین‌های امیدوار کننده‌ی روش سنتی جهت استحصال ترکیبات ارزشمند آن باشند.
<b>کلمات کلیدی:</b> خارمریم، ترکیبات زیست‌فعال، دی اکسید کربن فوق بحرانی، حلال به کمک مایکروویو.	
<b>DOI: 10.22034/FSCT.21.148.30.</b> مسئول مکاتبات: * mandana.bimakr@znu.ac.ir	