



Hydration Modeling of Rice (*Oryza Sativa*) by Empirical and Diffusion Models

Dalvi Isfahan, M. ^{1*}

1. Assistant professor, Department of Food Science and Technology, Faculty of Agriculture, Jahrom University, Jahrom, Iran.

ABSTRACT

In this study, water absorption characteristics of white rice during soaking at 25-65 °C was investigated. In the next step, the efficiency of fundamental and empirical models to predict the moisture content of grain during soaking were evaluated and compared. The fundamental models were developed by using analytical and numerical solutions of Fick's second law of diffusion based on regular shapes (cube and cylinder) and the real geometry of the white rice, respectively. Five empirical models (Henderson and Pabis model, exponential model, Page model, modified Page model and two-term exponential model) for explaining the soaking behavior of rice were also studied. The results of the studied models indicate that the numerical model were substantially more accurate than analytical model in describing the water absorption curves. The higher accuracy of numerical model can be attributed to the fact that this model selected appropriate shape to represent rice grains in the mathematical model. The average value of the effective water diffusivity at 25-65 °C was estimated to be in the order of 8.83×10^{-11} m²/s, by minimizing the error between experimental and numerically predicted results. Among the empirical models, the two-term exponential model was better than others in predicting changes in sample moisture during soaking. Overall, although both modeling approaches were able to predict the changes in moisture content of the sample during soaking, the numerical model was found to be more appropriate because it provided a more comprehensive understanding of the underlying physics of the process and the model parameters were directly related to measurable physical quantities.

ARTICLE INFO

Article History:

Received 2023/ 01/ 24
Accepted 2023/ 02/ 26

Keywords:

Rice,
Hydration,
Analytical model,
Numerical model,
Empirical model.

DOI: 10.22034/FSCT.20.134.87

DOR: 20.1001.1.20088787.1402.20.134.7.1

*Corresponding Author E-Mail:
dalvi@jahromu.ac.ir

1. Introduction

Rice is considered one of the main grains produced and consumed around the world. It is estimated that half of the world's population consumes this product daily. Before any type of processing and cooking of this product, a water absorption process is usually done through soaking. In general, water absorption (hydration) operations are widely used before various processes such as extraction, cooking, sprouting, conditioning and wet milling for legumes and grains, and it is necessary to know the behavior of water absorption in this category of products during hydration. is, because it significantly affects the subsequent processing operations and even the quality of the final product [1]. For example, the soaking process significantly reduces the cooking time of grains and will also soften the grain structure and remove anti-nutritional factors, starch gelatinization and protein denaturation. Determining the rate of water absorption in food formulation is also important. For example, the speed of water absorption can affect the order of adding dry ingredients to the mixture, or from this index, the amount of losses during the washing process or the amount of expansion of the grains in the can during the heating process can be determined [2]. In the case of rice, this The operation has a strong effect on the quality of cooking and the final texture of the product. In addition, the soaking process can significantly reduce the contamination of this product with heavy metals. For example, Feng et al. (2022) reported that soaking rice grains, especially in an acidic environment, can reduce cadmium between 45 and 85% [3]. The recommended soaking time for most rice grains is between 5-30 minutes for cooking in electric rice cookers, but longer soaking time (up to several hours) may be required for instant cooked rice, rice flour, and rice pudding.]4 [. Normally, the soaking temperature is determined below the starch gelatinization temperature and shows a positive correlation with the water content in soaked rice. However, soaking for a long time at low temperatures cannot produce the same texture as soaking at a higher temperature for a short time.

even though the moisture content of both samples is ultimately equal [5]. Considering that the soaking operation takes place at temperatures below the gelatinization temperature of starch. Soaking for a long time can also lead to the growth of microbes, and for this reason, the process time cannot be defined as long [3].

Water absorption is considered a mass transfer operation and follows the principle of diffusion or capillary flow depending on the structure and composition of grains. Hydration kinetics is also a complex phenomenon that usually shows two different behaviors in foods: concave-up shape and sigmoid shape. Concave shape is observed in most cereal grains, where at first the rate of water absorption is very high, but after reaching saturation or equilibrium moisture, it decreases significantly. On the other hand, sigmoid behavior has been observed absolutely for the seeds of the legume family, where a delay phase is observed at the beginning and ends with the hydration of the seed coat [6]. Modeling of water absorption process can be in two main forms of fundamental models¹ and modeling based on empirical relationships² In fundamental modeling based on the laws of water diffusion, solving Fick's second law is usually used analytically and numerically. In experimental models, mathematical relationships based on regression are used. Many researchers have reported the use of experimental and fundamental models to predict the hydration characteristics of food grains [7-9].

Although the modeling of rice water absorption process has already been investigated, studies that have developed 3D simulation are rare. Meanwhile, 3D simulation can help to improve our knowledge about this process and get a more correct understanding about this process. In addition, there has been no comparison between basic and experimental models regarding the soaking process. In this study, the aim of the present study is to investigate the effect of three different temperatures during soaking on the amount of rice water absorption in the thermal range of 25-65 degrees Celsius. In the next step of the research, two basic models that will be obtained by analytical and numerical solution methods will be developed, and in the next step,

¹. Fundamental

². Empirical

5 experimental models will be used to fit the data. And finally, the best model for rice water absorption will be determined.

2- Materials and methods

2-1- Initial preparation and soaking of seeds

Before use, the rice grains were cleaned of foreign materials and broken kernels and sieved to obtain samples of more uniform size. In the next step, the length, width, and height of at least 50 grains were determined using calipers and their average was used for modeling. The soaking process of rice grains was done for a different time period (0 to 100 minutes) and temperature conditions (25 to 65 degrees Celsius). For this process, 10 grams of rice (without any damage) was selected and placed in different mesh bags. After that, each bag was soaked in separate beakers containing distilled water (grain to water ratio 1:3 weight/volume) at three different temperatures, namely 25, 45 and 65 degrees Celsius. During the process of water absorption, the seeds were periodically drained at certain intervals, their surface moisture was dried with paper towels and weighed. The seeds were soaked again to continue the process for 100 minutes. The amount of moisture in each interval was determined based on wet weight [2 and 7].

2-2- Modeling - Penetration law (fic)

The second law of diffusion or Fick's equation was used to model water transport processes in rice.

The following assumptions were considered in solving the basic models.

*Rice with a homogeneous structure³ Is

* The shape and dimensions of the sample do not change during the operation. (It is worth noting that the results of Bakalis et al. (2009) and Prakash and Pan (2012) showed that the modeling of the process of water absorption and drying of rice grains is not affected by the change in rice size during the process [9, 10].

* The constant water penetration coefficient at any temperature is considered constant and the

effect of external resistance in mass transfer is ignored.

The diffusion equation in the analytical mode for two shapes of cylinder and cube is in the form of an infinite series [6].

In slab mode⁴, the mass transfer equation for each dimension of the cube was obtained from the following relationship and finally using the rule of community of effects⁵ The result was obtained for the cube.

$$\frac{C_s - C}{C_s - C_o} = \frac{4}{\pi} \sum_{n=0}^{\infty} \frac{(-1)^n}{2n+1} \cos\left(\frac{(2n+1)\pi x}{2L}\right) \exp\left(-\frac{(2n+1)^2 \pi^2}{4} Fo\right)$$

(1)

For Bi>40

$$\frac{C_s - C_{xyz}}{C_s - C_o} = \left(\frac{C_s - C_x}{C_s - C_o}\right)_x \left(\frac{C_s - C_y}{C_s - C_o}\right)_y \left(\frac{C_s - C_z}{C_s - C_o}\right)_z$$

(2)

In the above relationship, $C_s \cdot C_o L$, respectively, is the amount of moisture concentration in saturated state, the amount of initial moisture concentration and the next characteristic in each axis. F_o , is the Fourier number and is obtained from the following relationship.

$$F_o_x = \frac{Dt}{L_x^2}$$

(3)

In this relationship, D is the humidity penetration coefficient (square meters per second) and t is the time in seconds.

For the cylindrical shape, the moisture concentration changes as a function of time is obtained from the following equation.

$$\frac{C_s - C}{C_s - C_o} = \frac{4}{\pi} \sum_{n=0}^{\infty} \frac{\pi^2}{R^2 \delta_n^2} \exp(-R^2 \delta_n^2 Fo)$$

(4)

Both equation two and four can be used under the conditions of Biot's number greater than 40, initial condition, uniform initial concentration and boundary condition, constant concentration on the surface. Figure 1 shows the schematic image of the geometry of the analytical models in block and cylinder mode, as it can be seen that according to the actual shape of the rice grain, both geometries correspond almost to the actual shape of the grain.

The mass transfer equation based on Fick's

³. Isotropic

⁴. Slab

⁵. Principle of Superposition

second law for rice grain is determined from the following equation.

$$\frac{\partial C}{\partial t} = \frac{1}{r} \left[\frac{\partial}{\partial r} \left(rD \frac{\partial C}{\partial r} \right) + \frac{\partial}{\partial \theta} \left(\frac{D}{r} \frac{\partial C}{\partial \theta} \right) + \frac{\partial}{\partial z} \left(rD \frac{\partial C}{\partial z} \right) \right] \quad (5)$$

To solve the above equation, the boundary condition and the initial condition were determined as follows.

Boundary condition:

$$C(x,t) = C_{Tris} \quad (6)$$

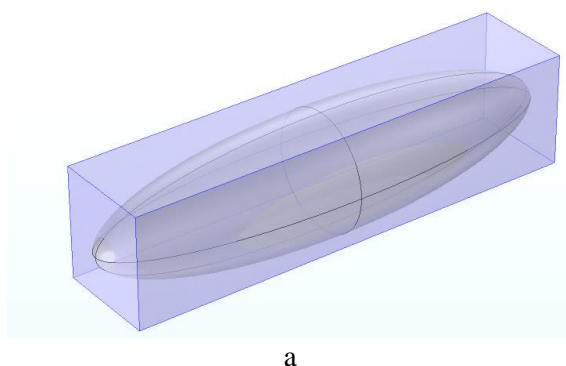

a

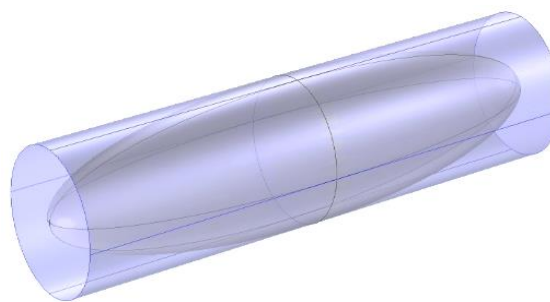

b

Fig 1 Schematic representation for the geometry of analytical models a) slab b) cylinder

Fitting experimental data and model using MATLAB software and curve fitting toolbox⁶ occurred.

Table 1 Mathematical models applied to the rehydration curves

No	Model	Analytical Expression
1	Exponential	$MR = \exp(-kt)$
2	Henderson & Pabis	$MR = A \exp(-kt)$
3	Page	$MR = \exp(-kt^n)$
4	Modified Page	$MR = \exp(-kt)^n$
5	Two-term	$MR = A_0 \exp(-k_0 t) + A_1 \exp(-k_1 t)$

2-3- Statistical analysis

To evaluate the fitting capacity of the models, two statistical criteria are the mean square error (MSE) and the coefficient of explanation (R^2) used. In these relations $y_{pre,i}$ and $y_{exp,i}$ They show the values predicted by the model and the observed values, respectively, and N is the total

Prerequisite:

$$C(x,0) = C_0 \quad (7)$$

that in these relations C_{Tris} and C_0 respectively, the equilibrium moisture content and the initial moisture content of rice grains [9].

5 experimental models (exponential, Henderson-Pabis, Page, modified Page and binomial exponential model) were used to describe rice water absorption at different temperatures (Table 1) [8].

number of observations [11].

$$MSE = \frac{1}{N} \sum_{i=1}^N (y_{pre,i} - y_{exp,i})^2 \quad (8)$$

$$R^2 = 1 - \frac{\sum_{i=1}^n (y_{pre,i} - y_{exp,i})^2}{\sum_{i=1}^n (y_{pre,i} - y_{exp,i})^2} \quad (9)$$

3- Discussion and results

The water absorption behavior of rice during the hydration process is presented in Figure 2. As it can be seen, at the beginning of the process, the rate of water absorption is high, but with the increase of time, the rate of absorption decreases and finally moves towards equilibrium or saturation humidity. The equilibrium moisture content of the sample in this rice variety was about 30%, which is similar to the results of Kashaninejad et al. (2007) who studied the water absorption rate in three varieties of Fajar, Shafaq and Neda, but the water absorption rate is

⁶.Curve Fitting Toolbox™

different from the results of Gong et al. The reason for this can be related to the type of cultivar, composition and internal structure of the cultivar [12 and 13]. Amylopectin, as the main ingredient of starch, has a structure with a high degree of branching, which allows it to easily combine with water molecules and create a very regular state in hydrated starch granules [14]. So that the water absorption curves also They reflect the amount of water absorption and the content of amylopectin, so that the higher the amount of amylopectin, the more water absorption. Dutta et al. (2016) who reported that waxy varieties obtained the highest water absorption among rice varieties during water soaking. Another thing that can be seen from the figure is the effect of temperature on the amount of absorption, so that with the increase in temperature, the power of water absorption in rice increases, which can be related to the increase in the penetration coefficient of food with the increase in temperature [15].

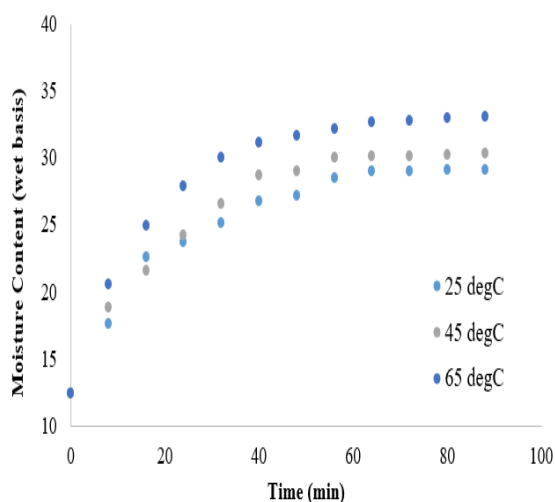

Fig 2 Kinetics of rice grain under different thermal conditions (25-65°C) during the soaking of the rice.

The value of effective diffusion coefficient was estimated by minimizing the error of experimental and numerical data. This work using the simplex optimization method⁷It was done in MATLAB software [9]. The estimated value of the effective diffusion coefficient in the temperature range of 25-65 degrees Celsius, respectively¹¹ $10 \times 95/7$ ⁻¹⁰ 1.04×10 (square meters per second) was obtained, which is

⁷. Simplex Optimization Method

consistent with the results of other researchers [8 and 16].

The comparison between the results of the moisture content of the sample at three different temperatures using analytical and numerical equations is given in Figure 3. As can be seen, in all three temperatures, the results obtained from the numerical model have been able to predict the humidity changes in the sample with higher accuracy, this issue has been determined through the statistical criteria of the coefficient of explanation and the mean square error (Table 2). The reason for this is due to the higher accuracy in the geometry considered for the rice grain by the numerical model. Because, as explained in the materials and methods section, the two analytical models developed are based on rectangular and cylindrical cube shapes, but the numerical model considers the rice grain to be oval. The importance of choosing the right and accurate geometry for rice grain has also been noted in previous studies, Prakash et al. (2012) reported that using models with simpler geometric shapes (sphere and cylinder) for rice grain during drying It will lead to errors in the prediction of drying characteristics such as moisture content and moisture gradient. These researchers have introduced the best geometric shape for rice grain as an oval, which is consistent with the results of this research [10].

Figure 4 shows the changes in the moisture content of the sample at the geometric center of the rice grain at three different temperatures. As can be seen, the same trend is observed in all three temperatures, and the rate of moisture absorption in the cylindrical geometry is the lowest, and in the case of the numerical model, which shows the actual shape of the rice grain, the rate of moisture absorption is the highest. Another point that can be seen from the figure So, the rate of water absorption in the center is slow and slower than the average water absorption of the rice grain, which seems quite logical, because in this case, the water must travel a greater distance to penetrate the center of the grain.

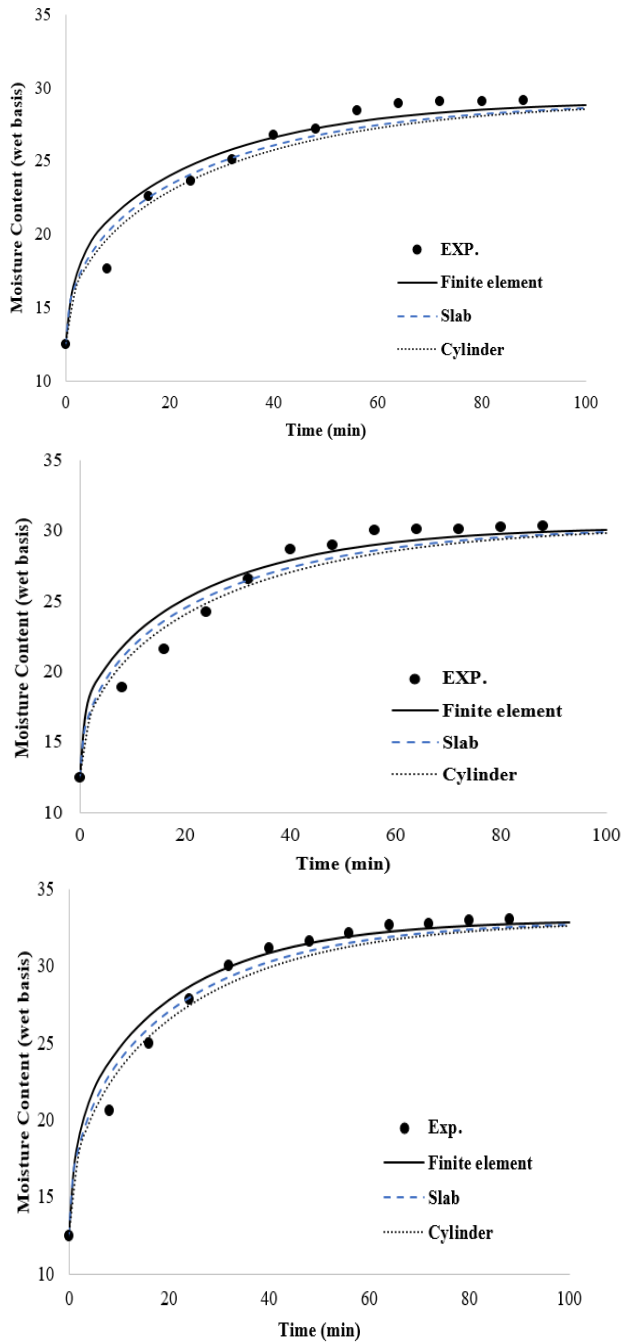

Fig 3 Comparison of numerical and analytical predictions with experimental results at 3 different temperatures ($a= 25, b= 45$ and $c= 65$ °C).

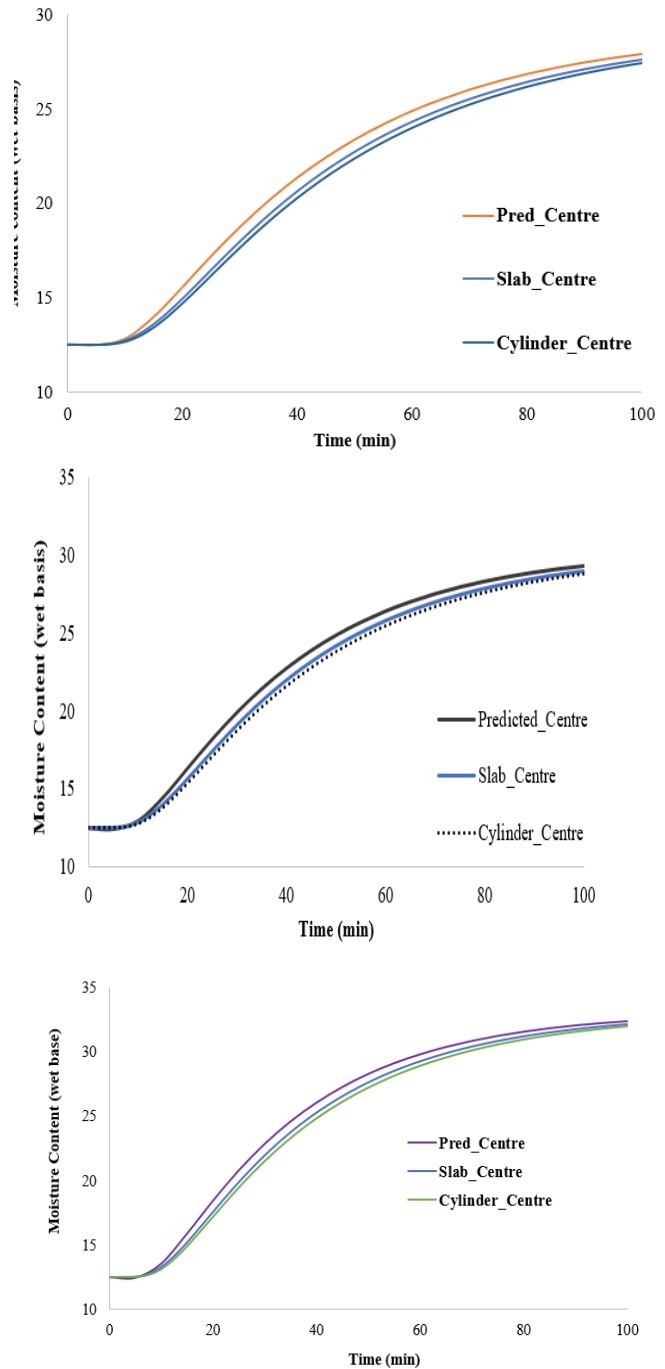

Fig 4 Comparison of numerical and analytical predictions at centre point at three different temperatures (25, 45 and 60 °C)

Table 2 Statistical results obtained for two analytical and numerical models

Temp (°C)	25		45		65		
	Model	R ²	MSE	R ²	MSE	R ²	MSE
	Numerical model	0.991	0.604	0.986	1.063	0.995	0.439
	Analytical model (Slab)	0.998	0.953	0.984	1.337	0.993	0.720
	Analytical model (Cylindrical)	0.990	1.13	0.986	1.398	0.994	0.815

Figure 5 shows contour diagrams of moisture content at different times. It can be seen that moisture is slowly absorbed by the boundary layer and the highest and lowest amount of moisture is located in the boundary layer and the geometric center of the rice grain, respectively. By increasing the duration of soaking, water absorption increases and the gradient of humidity difference between different points decreases drastically. For example, after 5 minutes from the start of the process, this difference in concentration is 18, but with the increase of soaking time to 90 minutes, this difference reaches less than one unit, which indicates reaching the equilibrium state in all parts of the rice. Takeuchi et al. (1997) studied water absorption and moisture distribution in rice grain during boiling using nuclear magnetic resonance (NMR) and found that the moisture profile obtained by solving the diffusion equation was similar to the moisture profile obtained by NMR. [10 and 18].

Table 3 and Figure 6 show the values of the constant coefficients of the 5 studied water absorption kinetic models that were fitted using laboratory data. In order to determine the best model, two statistical indicators, the coefficient of explanation (Equation 8) and the mean squared error (Equation 9) were used. Based on these two indicators, the higher the explanation coefficient and the lower the average squared error, the more appropriate the model is for describing the changes in water absorption kinetics [1]. According to the above two indicators, although all 5 models were able to accurately predict the changes in the water absorption rate of the sample at different temperatures, but the best binomial representative model was selected. Binomial model coefficients (A_0 and A_1) showed decreasing and increasing trends with increasing temperature, respectively.

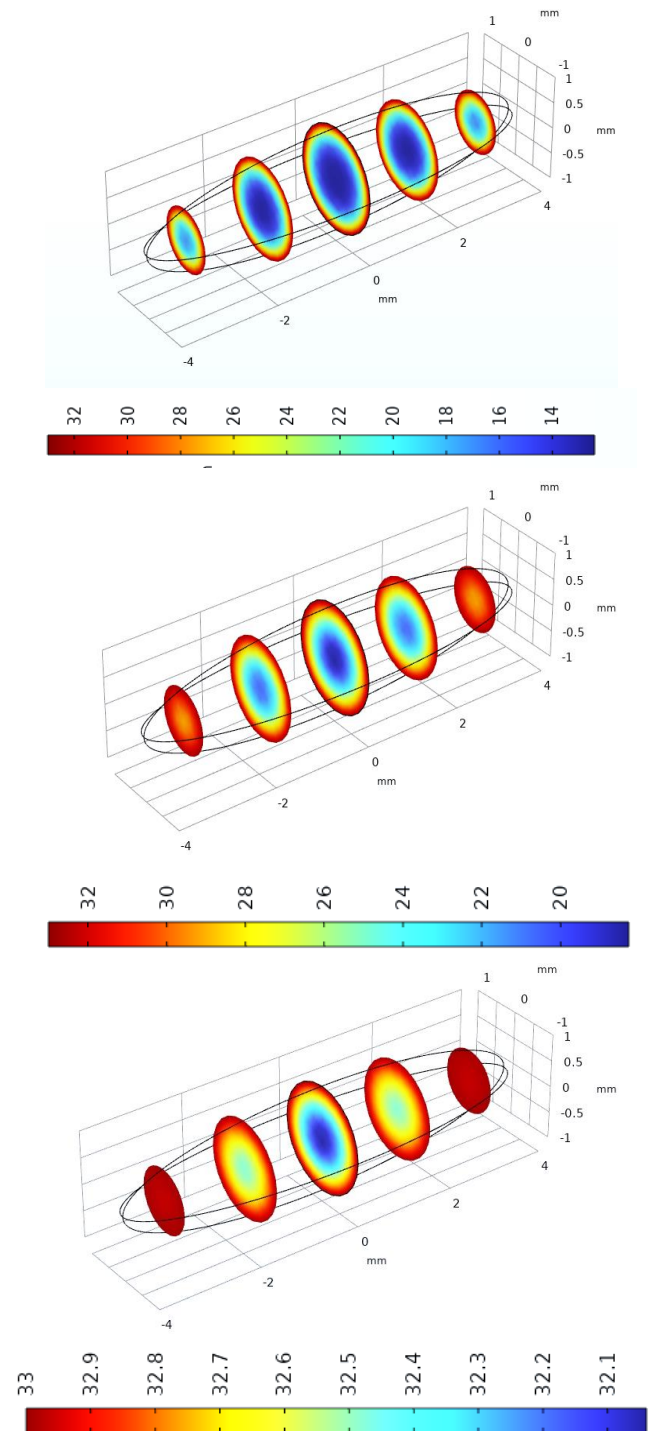
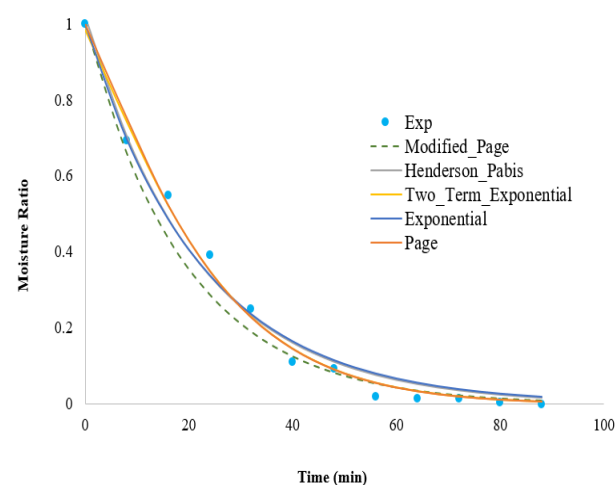
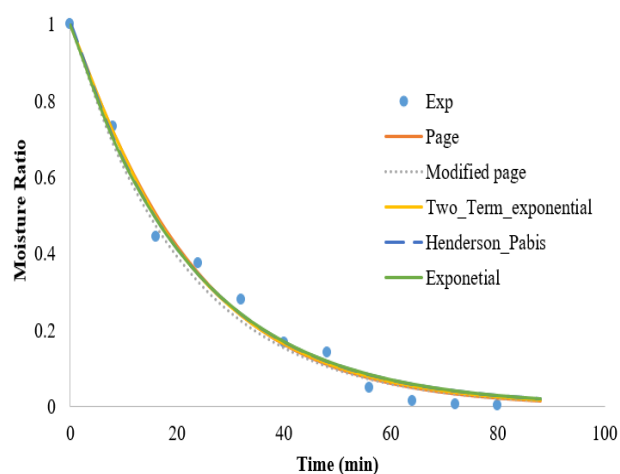

Fig5 Contours of moisture content in the rice grains at 5, 20 and 90 minutes after soaking.

Table 3 Results of statistical analysis on the modeling of rehydration

Model	Temp. (°C)	Constant	R ²	MSE
Exponential	25	k=0.044	0.991	9.48E-04
	45	k=0.045	0.989	1.42E-03
	60	k=0.050	0.999	1.03E-04
Henderson & Pabis	25	A=1.010 k= 0.044	0.990	9.35E-04
	45	A=1.022 k= 0.046	0.988	1.36E-03
	60	A=1.006 k=0.051	0.999	9.90E-05
Page	25	k=0.035 n= 1.065	0.990	8.56E-04
	45	k=0.023 n= 1.194	0.992	7.83E-04
	60	k=0.043 n=1.047	0.999	9.90E-05
Modified Page	25	k=0.0437 n=1.065	0.989	1.09E-04
	45	k=0.0433 n=1.192	0.980	2.49E-03
	60	k=0.0503 n= 1.047	0.998	1.69E-04
Two-term exponential	25	A ₀ =-9.207 k ₀ =0.061 A ₁ =10.204 k ₁ =0.059	0.991	8.34E-04
	45	A ₀ =-9.424 k ₀ =0.075 A ₁ =10.410 k ₁ =0.070	0.993	7.21E-04
	65	A ₀ =-12.609 k ₀ =0.067 A ₁ =13.609 k ₁ =0.066	0.999	5.44E-05

In the comparison between two approaches in process modeling (fundamental and experimental), the fundamental models and especially the numerical model because they were based on physical, diffusion or diffusion theory, were able to provide a more detailed analysis regarding the method of product moisture absorption mechanism. At the same time, this model can be easily generalized for the seeds of other cereals, with different sizes and different initial and boundary conditions, but the experimental models can only be used within the limits of the tested conditions. In addition, in fundamental models, unlike experimental models, the parameters of the model provide a physical quantity that can be measured, for example, the parameter of diffusion coefficient or diffusion coefficient [1 and 4].



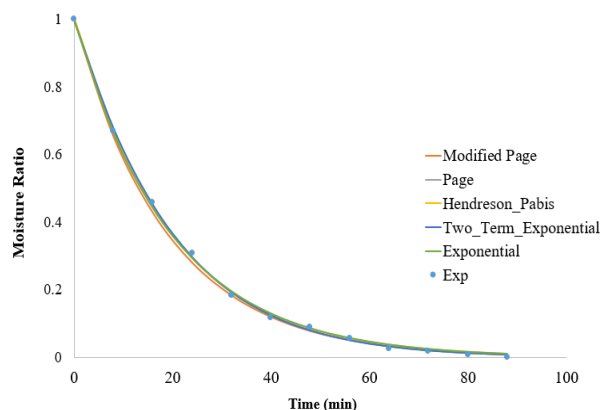

Fig 6 Comparison of moisture ratios determined by experimentation and prediction using different empirical models at three different temperatures (25, 45 and 65 °C)

Figure 7 shows the changes in rice moisture as a function of time and rice diameter in three dimensions. Using this diagram, the moisture content of rice can be determined at any moment as a function of the diameter of the rice grain. As expected, with increasing time, the water absorption rate of the sample increases and after about 30 minutes, it has moved towards equilibrium conditions. In addition, the rate of water absorption in the central point of the rice is slower than the other points and reaches the equilibrium state later, while the border points absorbed water quickly and reached the equilibrium state after a very short period of time.

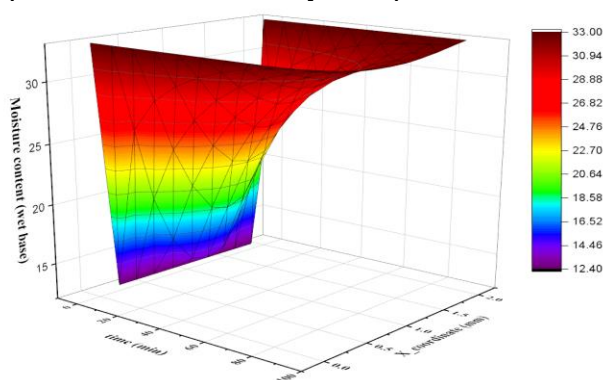

Fig 7 Predicted moisture content distribution during soaking at 45°C

4 - Conclusion

In this study, the water absorption process of rice grains was investigated as a function of temperature 25-65 degrees Celsius. In the next step, two modeling approaches (fundamental and experimental) were developed to predict changes

in moisture content as a function of temperature and time. the results showed that:

1- With increasing temperature, the rate of moisture absorption and the equilibrium moisture content of rice grain increase.

2- Among the basic models, the numerical model that was solved based on the finite element method showed the best results and agreement with the experimental data. The reason for this could be related to the more precise geometric shape used in this model, as it was developed based on the actual shape of the sample.

3- Among the 5 experimental models tested, the binomial representative model showed the best fit with the experimental data.

4- The amount of effective diffusion coefficient was determined using the inverse method and the results showed that the values of this coefficient depended on temperature and showed an upward trend with increasing temperature. The value of this coefficient was in the range between 7.95-10-11 - 1.04-10-10 (square meters per second).

In the continuation of this study, the effect of various chemical and mechanical treatments and their effect on water absorption speed and penetration coefficient will be investigated.

5- Resources

- [1] Shafaei, S. M., Nourmohamadi-Moghadami, A., & Kamgar, S. (2016). Development of artificial intelligence based systems for prediction of hydration characteristics of wheat. *Computers and Electronics in Agriculture*, 128, 34-45.
- [2] Maskan, M. (2001). Effect of maturation and processing on water uptake characteristics of wheat. *Journal of Food Engineering*, 47(1), 51-57.
- [3] Feng, W., Fan, D., Li, K., Wang, T., Zhang, H., Zhou, X., Wan, J., & Wang, R. (2022). Removal of cadmium from rice grains by acid soaking and quality evaluation of decontaminated rice. *Food Chemistry*, 371, 131099.
- [4] Zhu, L., Cheng, L., Zhang, H., Wang, L., Qian, H., Qi, X., & Wu, G. (2019). Research on migration path and structuring role of water in rice grain during soaking. *Food Hydrocolloids*, 92, 41-50.
- [5] Maskan, M. (2002). Effect of processing on

- hydration kinetics of three wheat products of the same variety. *Journal of Food Engineering*, 52(4), 337-341.
- [6] Kalita, D., Jain, S., Srivastava, B., & Goud, V. V. (2021). Sono-hydro priming process (ultrasound modulated hydration): Modelling hydration kinetic during paddy germination. *Ultrasonics Sonochemistry*, 70, 105321.
- [7] Kashaninejad, M., Dehghani, A. A., & Kashiri, M. (2009). Modeling of wheat soaking using two artificial neural networks (MLP and RBF). *Journal of Food Engineering*, 91(4), 602-607.
- [8] Kashaninejad, M., Maghsoudlou, Y., Rafiee, S., & Khomeiri, M. (2007). Study of hydration kinetics and density changes of rice (Tarom Mahali) during hydrothermal processing. *Journal of Food Engineering*, 79(4), 1383-1390.
- [9] Bakalis, S., Kyritsi, A., Karathanos, V. T., & Yanniotis, S. (2009). Modeling of rice hydration using finite elements. *Journal of Food Engineering*, 94(3), 321-325.
- [10] Prakash, B., & Pan, Z. (2012). Effect of Geometry of Rice Kernels on Drying Modeling Results. *Drying Technology*, 30(8), 801-807.
- [11] Dalvi-Isfahan, M. (2020). A comparative study on the efficiency of two modeling approaches for predicting moisture content of apple slice during drying. 43(11), e13527.
- [12] Kashaninejad, M., Chabra, D., Rafiee, Sh. Study of water absorption and physical properties changes of rice varieties during soaking process. 2008. *Journal of Agriculture and Natural Resources Sciences*. 15 (2). 163-175 [Persian].
- [13] Gong, M., Zhou, Z., Jin, J., Yu, Y., Liu, S., Han, X., Zhong, F., & Mao, J. (2020). Effects of soaking on physicochemical properties of four kinds of rice used in Huangjiu brewing. *Journal of Cereal Science*, 91, 102855.
- [14] Yu, S., Ma, Y., Menager, L., & Sun, D.-W. (2012). Physicochemical Properties of Starch and Flour from Different Rice Cultivars. *Food and Bioprocess Technology*, 5(2), 626-637.
- [15] Dutta, H., Mahanta, C. L., Singh, V., Das, B. B., & Rahman, N. (2016). Physical, physicochemical and nutritional characteristics of Bhoja chaul, a traditional ready-to-eat dry heat parboiled rice product processed by an improvised soaking technique. *Food Chemistry*, 191, 152-162.
- [16] Roca, E., Broyart, B., Guillard, V., Guilbert, S., & Gontard, N. (2007). Controlling moisture transport in a cereal porous product by modification of structural or formulation parameters. *Food Research International*, 40(4), 461-469.
- [17] Takeuchi, S., Maeda, M., Gomi, Y.-i., Fukuoka, M., & Watanabe, H. (1997). The change of moisture distribution in a rice grain during boiling as observed by NMR imaging. *Journal of Food Engineering*, 33(3), 281-297.
- [18] Fan, D., Ma, S., Wang, L., Zhao, H., Zhao, J., Zhang, H., & Chen, W. (2013). ¹H NMR studies of starch-water interactions during microwave heating. *Carbohydrate Polymers*, 97(2), 406-412

مدل‌سازی هیدراتاسیون برنج (*Oryza Sativa*) توسط مدل‌های تجربی و نفوذ

محسن دلوی اصفهان*

۱- استادیار گروه علوم و صنایع غذایی، دانشکده کشاورزی، دانشگاه جهرم، جهرم، ایران.

اطلاعات مقاله	چکیده
تاریخ های مقاله :	<p>در این مطالعه ویژگی های جذب آب برنج سفید در حین خیساندن در دمای ۲۵-۶۵ درجه سانتی گراد تعیین شد. در مرحله بعد، کارایی مدل‌های بنیادی و تجربی برای پیش‌بینی میزان رطوبت دانه در حین خیساندن مورد ارزیابی و مقایسه قرار گرفت. مدل‌های بنیادی با استفاده از حل تحلیلی و عددی قانون دوم انتشار فیک بر اساس اشکال منظم (مکعب و استوانه) و هندسه واقعی برنج سفید به ترتیب توسعه داده شدند. ۵ مدل تجربی نیز (مدل هندرسون و پاییس، مدل نمایی، مدل پیچ، مدل پیچ اصلاح شده و مدل نمایی دو جمله‌ای) برای توضیح رفتار خیساندن برنج نیز مورد مطالعه قرار گرفت. نتایج مدل‌های مورد مطالعه نشان داد که مدل عددی به طور قابل توجهی از مدل تحلیلی در توصیف منحنی‌های جذب آب دقیق‌تر است. دقت بالاتر مدل عددی را می‌توان به این دلیل نسبت داد که این مدل شکل مناسبی را برای نشان دادن دانه های برنج در مدل ریاضی انتخاب کرد. مقدار متوسط ضریب نفوذ موثر در دامنه درجه حرارت ۲۵-۶۵ درجه سلسیوس $10^{-11} \times 8/83$ (متر مربع بر ثانیه) با روش کمینه سازی خطا بین داده های تجربی و مدل به دست آمد. در بین مدل‌های تجربی، مدل نمایی دو جمله‌ای بهتر از سایر تغییرات رطوبت نمونه در طول خیساندن را پیش‌بینی کرد. به طور کلی، اگرچه هر دو رویکرد در مدل‌سازی قادر به پیش‌بینی تغییرات رطوبت نمونه در طول خیساندن بودند، مدل عددی مناسب‌تر بود، زیرا درک جامع‌تری از فیزیک فرآیند را ارائه داد و پارامترهای مدل مستقیماً با مقادیر فیزیکی قابل اندازه گیری مرتبط هستند.</p>
تاریخ دریافت: ۱۴۰۱/۱۱/۰۴ تاریخ پذیرش: ۱۴۰۱/۱۲/۰۷	
کلمات کلیدی: برنج، جذب آب، مدل تحلیلی، مدل عددی، مدل تجربی.	
DOI: 10.22034/FSCT.20.134.87 DOR: 20.1001.1.20088787.1402.20.134.7.1	
* مسئول مکاتبات: dalvi@jahromu.ac.ir	