



Scientific Research

Feasibility of degumming and neutralization of crude rapeseed oil using polyvinylidene fluoride membrane

Maryam Rashidian¹, Maryam Gharachorloo², Manochehr Bahmaei³, Mehrdad Ghavami⁴, Hossein Mirsaied Ghazi⁵

1-PhD graduated of Food Science and Technology, Science and Research Branch, Islamic Azad University, Tehran, Iran.

2-Professor of Food Science and Technology, Science and Research Branch, Islamic Azad University, Tehran, Iran.

3-Associate Professor of Department of Chemistry, Tehran North Branch, Islamic Azad University, Tehran, Iran.

4-Professor of Food Science and Technology, Science and Research Branch, Islamic Azad University, Tehran, Iran.

5-Associate Professor of Department of Food Technology, University of Tehran, Tehran, Iran.

ARTICLE INFO

ABSTRACT

Article History:

Received: 2024/4/30

Accepted: 2024/7/20

Keywords:

Canola oil,
membrane,
filtration,
permeate flux,
phosphatides,
acidity,
color

Current research, has evaluated the efficiency of the membrane process in degumming and neutralization of crude rapeseed oil. Crude rapeseed oil miscellas were prepared using hexane solvent with 20:80 and 30:70 ratios. In order to degumming, the micella passed through the membrane after adding 0.3% of 85% (w/w) phosphoric acid, under three pressure levels of 2, 3, and 4bar and two flow speed of 0.5 and 1m/s; Then, for neutralization, after adding NaOH aqueous solution in two concentrations of 10% and 30% (w/v) the micella passed through the membrane, under the previous conditions, as well as three temperature levels of 30, 40 and 50°C. The results showed that for 20:80 micella, the flux gradually decreased with the passage of time and reached a stable state after about 20 minutes. Surveying the simultaneous effect of conditions throught the neutralization process for 20:80 micella, revealed that the highest flux corresponds to 40°C, 4bar, 1.0m/s. Surveying the simultaneous effect of temperature, pressure and flow rate throught the neutralization process for 30:70 micella, has also revealed that the highest flux corresponds to 50°C, 2bar, and 1.0m/s. The results of the physicochemical tests also revealed that there is no significant difference in the levels of phosphorus and phosphates in both membrane filtration and conventional refining methods ($p < 0.01$); But acidity reduction for membrane filtration method was significantly higher than that of classical refining method ($p < 0.01$). The reduction of peroxide index was also significantly higher for classic refining method than membrane filtration method ($p < 0.01$). In terms of color, the results showed that the membrane filtration method was not able to reduce the yellow color in crude oil, while the classic refining method significantly reduced the yellow color ($p < 0.01$). The red color index for the classic method also had a significant decrease compared to the membrane method ($p < 0.01$).

DOI: 10.22034/FSCT.21.156.167.

*Corresponding Author E-
M_Gharachorlo@srbiau.ac.ir

1-Introduction

Fats and oils are important components of foods [1], and among them, rapeseed oil is of particular importance and is one of the five vegetable oil products that are used the most all over the world [2]. The conventional refining process can lead to many qualitative harms such as hydrolysis, oxidation, polymerization and structural changes in the oil [3]; Therefore, finding an alternative process for it is important and necessary. In the meantime, membrane processes for various reasons such as saving energy consumption, not using chemical pollutants, improving product quality, preserving nutrients and other desirable oil compounds, reducing the volume of wastewater or eliminating the wastewater treatment process, ease of operation and The process at low and normal temperatures as an alternative method has been much considered [4].

San Gupta¹ In 1977 and 1986, as a pioneer in this matter, he used ultra-refining technique to remove gum from oily misela [5]. Abdullah² et al. [6] degummed crude canola oil using a membrane method and showed that a 5 kDa ceramic membrane was able to remove 95% of phospholipid from the oil. Moore and Gogat³ [7] while degumming soybean oil using a three-stage combined membrane process showed that the use of this membrane resulted in almost complete removal of phospholipids (>99.9%) and a 91.49% reduction in crude oil color.

he⁴ and colleagues [8] also showed that the membrane process is able to completely remove phospholipids from the membrane; Also, their results showed that the use of the mentioned membrane did not have much effect on the reduction of free fatty acids. Cao⁵ et al. [9] also reported that the passage of tea seed oil micelles through the membrane can reduce the oil peroxide content by 29.2% and free fatty acids by 16.2%.

The above material shows that membrane technology has a high potential in the field of processing and refining edible oils. Considering the growing trend of production of membranes resistant to various operating conditions and chemical substances, and increasing the use of this new technology in various industries, determining the best conditions for the membrane process to remove resins and soapy

compounds, causing valuable savings in consumption Energy is obtained and a large amount of nutritional value of edible oils is preserved. Therefore, in this research, the feasibility of degumming and neutralization of crude canola oil using polyvinylidene fluoride membrane was discussed.

2- Materials and methods

To perform the experiments, raw canola oil was provided from Mahidasht Kermanshah Industrial Complex (Nazgol Edible Oil). The membrane used is a microrefining membrane made of polyvinylidene fluoride⁶ (PVDF) was made in America with a pore size of 0.22 micrometers and an active area of 109 cm² in non-continuous flow mode. The used system includes a feed tank, centrifugal pump, pressure gauge, heat exchanger, membrane, inverter and flow control valve. In all stages of membrane purification of canola oil, hexane solvent (Salar Chem, Iran) was used in the form of Misla (80% oil + 20% hexane) (70% oil + 30% hexane).

1-2-Membrane operation method in gum extraction and neutralization

To perform the micro-refining operation, crude rapeseed oil miscella was first prepared with solvent ratios of 20 and 30 (wt/wt). The solvent used to make misla was hexane. Then, 0.3% (weight ratio) 85% phosphoric acid was added to the formed misla at room temperature and stirring was done at high speed for 30 minutes, after which the formed misla was added to the gumming process. It was passed through the PVDF membrane for sixty minutes. After degumming from the misela, in the second step, an aqueous solution of NaOH was added to the desired misela in two concentrations. This operation was done at room temperature using a pipette based on the amount of fatty acids in the oil and very slowly, and the contents of the misela were mixed using a magnetic stirrer at 100 rpm, and finally the misela containing soda was introduced into the feeding tank. And after reaching the desired temperature (30, 40 and 50 degrees Celsius), the separation operation of the soap formed by the PVDF membrane was carried out for sixty minutes. In the gum extraction stage, three pressures of 2, 3 and 4 bar and two flow rates of 0.5 and 1.0 meters per second and also in the neutralization stage of three pressures of 2, 3 and 4 bar, two flow rates of 0.5 and 0 1/m/s and

1 - Late Gupta
2 -Abdellah
3 -More & Gogate

4 -New
5 -High
6 -Polyvinilidene fluride

three temperatures of 30, 40 and 50 degrees Celsius were used to check the performance of simultaneous separation of gums and neutralization of misela. At the end of each operation, a new membrane was used, although the membrane washing cycle can also be used to lower the cost.

2-2- Membrane system used

In this research, a MF microrefining membrane system was used. This system included a feeding tank, pump, pressure gauge, heat exchanger, membrane module, inverter and flow control valve. Figure (1) schematically shows the transverse and non-continuous flow system⁷ Used in the micro-refining process. In this system, water was first poured into the tank and the flow was adjusted manually and the pressure was adjusted using the inverter and transmitter. Oil poured into the tank by the pump (PROCON, Series 2, Milano, Italy) was drawn and delivered to the inlet of the membrane

module. feed flow⁸ After passing through the membrane into two permeable parts⁹ and natraveh¹⁰ It was divided and transferred to the collection container and the primary tank through the two outlets built on the module, respectively. The used plate membrane was placed inside the plate module and the module was sealed against fluid leakage.

Two pressure gauges were placed on the sides of the module to show the input and output pressure of the system. Also, a regulator of pump motor speed or inverter¹¹ (SV004ic6-1, KOREA) together with a flow regulating valve located on the way back to the tank, were responsible for regulating the pressure and the output flow, respectively, on the way back to the tank. A digital scale (Mettler Toledo, Switzerland) with an accuracy of 0.1 gram was used to measure the weight of the sap oil, which was placed under the sap collection container.

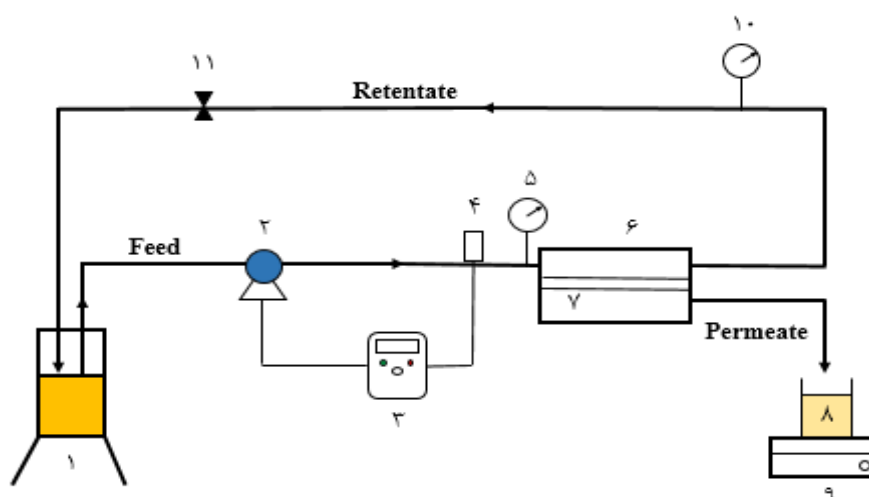

Figure 1 Schematic of the microfiltration system (1- feed tank 2- pump 3- inverter 4- transmitter 5- input pressure gauge 6- membrane module 7- membrane 8- permeate collection tank 9- scale 10- output pressure gauge 11- flow control valve).

3-2- Calculation of membrane transfer pressure

As mentioned, membrane technology is a pressure-driven process. The pressure changes along the channel in which the membrane is located. Therefore, researchers to solve this problem, membrane transfer pressure¹² (pD) defined in membrane processes and used it to report the pressure

used in the process, which was calculated from equation (1) in this study:

$$(1) \quad \Delta p = \frac{p_b + p_a}{2}$$

in which p_b Pre-membrane pressure and p_a The pressure is after the membrane.

2-4- Calculation of permeation flux

Permeation flux ($J_p, \frac{kg}{m^2s}$) refers to the amount of permeability obtained from the unit of membrane surface per unit of time,

7 . Batch
8 . Feed
9 . Permeate

10 . Retentate
11 . Inverter
12 . Trans Membrane Pressure

which was calculated from equation (2) [21 and 22]:

$$(2) \quad \frac{\Delta m}{A \times t} J_p =$$

where m (kg) is the value of the weight of the resulting permeability at time t (s) is at the surface A (m²) of the membrane. In some cases, the flux is measured in terms of volume instead of weight, where instead of m (kg) from v (m³) (resulting volume of percolation) is used.

2-5- The study of different mechanisms of membrane clogging

The main factor limiting the use of membrane processes under pressure is clogging, which is due to the accumulation, deposition and absorption of small particles on the surface of the membrane and the deposition of finer soluble substances between the pores of the membrane. As seen in chapter one, there are four main mechanisms for membrane clogging, including complete blocking, intermediate blocking, cake formation and standard blocking.

Hermiya [10] created a rule that can be used to determine which of the above-mentioned blocking mechanisms is dominant. According to this law, from the curve of changes in the volume of transpiration (v) with respect to time (t) we can understand the dominant clogging mechanism in the process. in such a way that:

a) If the curve $\frac{t}{v}$ relative to v The cake formation mechanism is the dominant mechanism.

b) If the curve $\frac{t}{v}$ relative to t Linear is the dominant standard blocking mechanism.

c) When the middle blocking mechanism is dominant, the curve $Ln(t)$ relative to v It will be linear.

The above three rules show the dominant clogging mechanism in the whole processing; But in any process, all mechanisms can be effective, and depending on the conditions at any time, one

mechanism is the dominant mechanism. In order to know which mechanism is dominant at any time, Hermiya presented the relation (3):

$$(3) \quad \frac{d^2 t}{dv^2} = k \left(\frac{dt}{dv} \right)^i$$

In the above relation k clogging factor and i It is a blocking index. amount ^{i} It shows the blocking mechanism or index in such a way that:

a) If $i = 0$ The dominant mechanism is cake formation.

b) if $i = 1$ The dominant mechanism is intermediate blocking.

c) If $i = 1.5$, standard blocking is the dominant mechanism.

d) if $i = 2$ Therefore, the dominant mechanism is complete blocking.

6-2- Determining the highest output flow rate

Since the purpose of the research was to evaluate the potential of the MF process to replace it in the industry with conventional methods, therefore, it is very important to determine the output flow rate in the process for a more detailed investigation. Dubai It is called the amount of fluid that per unit of time from a certain level passes In general, it is possible Dubai into two categories Debbie Jeremy¹³ and volume flow¹⁴ divided To determine the best output flow rate, the amount and time of the canola oil misela process (20 and 30) and the highest and best flow rate were determined.

7-2- Solvent removal from oil

After passing the miscella through the membrane and in order to remove the solvent from the oil, steam was injected into the mixture of hexane and oil. Hexane, which is a volatile solvent, was easily separated from the oil and steamed to the cooling section and reused as liquid. In addition to the above method, a rotary evaporator was also used to efficiently and gently remove the solvent from the samples. The rotary device was used because water and solvent had a lower

13- mass flow rate

14- volumetric flow rate

boiling point at reduced pressure, so hexane was evaporated at a temperature of 40 degrees Celsius and removed to determine the amount of oil in the liquid and then to check the quality of the refined oil. The following chemical tests were performed on them.

8-2- The classic method of gum removal and neutralization

First, phosphoric acid and soda with 14 degree of bome are added to crude oil in the step of degumming and neutralization, respectively, according to the amount of free fatty acid and mixed at 70 to 80 degrees Celsius. After that, soap is separated by separator I and II. Then the oil is washed to remove the remaining soap in the oil and the oil is dried under vacuum. After this, the oil enters the decolorization stage and passes through the filter press at a temperature of 85 degrees Celsius under vacuum. At this stage, soil is added to the oil, after which the oil enters the deodorization stage to remove free fatty acids and substances that create taste and smell. Samples are taken and physicochemical tests are performed at all stages from crude oil to deodorization. Then the results were compared with the membrane method.

9-2- Physicochemical analyses

In order to compare between oil refined by classical method and oil refined by membrane filtration, phospholipids, peroxide number, acidity and color were compared between these two types of oil, and the measurement method of each of these criteria is presented below:

The content of phosphorus was measured by the standard blue molybdenum method using the AOCS method ca 12-55 [11]. The amount of peroxide in the oil was also expressed in terms of milliequivalent grams of active oxygen for one kilogram of oil and was determined as 4179 based on the national standards of Iran [12]. Acidity was also measured by titration method according to Iranian national standard No. 4178 [13]. Finally, the AOCS Cc 13e_02 [14] method was used to measure the color, and the color

of the oil was calculated using standard numbered colored glasses.

10-2- Statistical analysis

In order to investigate the process of oil purification by the membrane passage method, experiments were conducted in a factorial manner and based on a completely randomized design with 48 treatments in two stages. In the first step, after adding phosphoric acid to each of the micellar, the degumming process at two flow rates and three pressure levels (12 treatments in total) and in the next step by adding soda to the degummed misla, the neutralization process at two flow rates. Three pressure levels and three temperature levels (a total of 36 treatments) were completed in the purification process and finally, the most optimal conditions in terms of the maximum permeate flux and the least clogging and membrane resistance were selected for purification. All statistical calculations and data analysis using software SAS (ver 9.1) was performed. To compare the averages, Duncan's test was used and graphs were drawn with Excel software.

3- Findings and discussion

In this section, the effect of speed, pressure, and temperature on the efficiency of achieving transparency in the gumming and neutralization stages for each of the two crude canola oil mixtures (with ratios of 20:80 and 30:70) was investigated, and then the dominant mechanism Constipation was determined in each treatment. Then, according to the obtained results, the best passing flux, pressure and temperature for higher flux and consequently less membrane clogging in the neutralization stage were selected as the optimal treatment.

1-3- The effect of pressure on the seepage flux of canola mille 20:80 in the gumming stage

Figure (2) shows the effect of pressure on the gumming process of canola oil (20:80) at a constant speed of 0.5 and 1 m/s. The results showed that with the passage of time, the percolation flux gradually decreased and

reached a stable state after about 20 minutes. The time required to reach this steady state depends on the characteristics of the feed, the type of membrane and the conditions governing the operation (temperature, pressure and flow rate). The reason for reaching stable conditions is probably the balance of the reverse diffusion coefficient and the convective transfer rate of materials to the membrane surface [15 and 16]; Also, it was found that, in general, with the increase in pressure, the amount of seepage flux has increased; The reason for this phenomenon can be increased driving force¹⁵ The convective flow is attributed to the membrane surface, which is in accordance with Darcy's law. In other words, an increase in pressure in a certain range leads to an increase in the permeate flux, and at higher pressures, the permeate flux is under the control of the mass transfer process. The pressure at which the permeate flux reaches a constant limit can be considered as the

optimal pressure. At this pressure, the permeate flux reaches its maximum and has a slight tendency to form a cake layer on the surface of the membrane [17].

As can be seen from Figure (2), the difference in the amount of seepage flux in different pressures is greater in the initial non-equilibrium conditions, and with the increase in the transverse pressure difference, the seepage flux also increased, which indicates that the seepage flux is used in operational conditions. in this range depends on the transverse pressure difference. The obtained results are similar to previous works, for example, Rafe et al. [15] reported that canola oil impurities, especially phospholipids, lead to an increase in hydraulic resistance and membrane clogging. In addition, Pagliero [18] was able to purify a 25% soybean oil hexane mixture well using an inorganic membrane module and reported similar results.

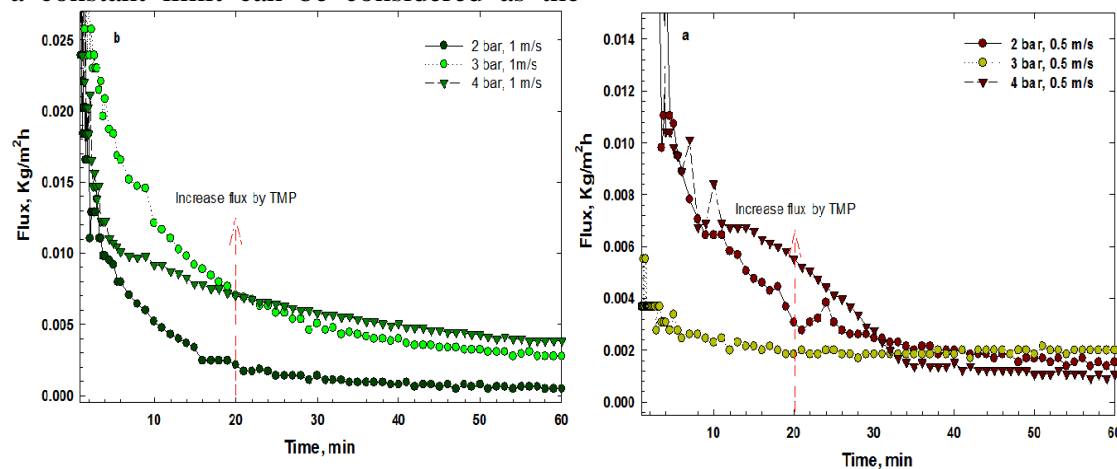

Figure 2 the effect of pressure on permeate flux through degumming process of canola oil micella (20:80).

2-3- Effect of flow speed on seepage flux of canola millet 20:80

In figure (3), the effect of flow speed of 0.5 and 1 m/s at constant pressures of 2, 3 and 4 bar on the permeation flux of Misela is given. As can be seen, at low pressures, due to less accumulation of particles on the surface of the membrane, the flow rate did not have a significant effect on the permeate flux; But at higher pressures, with the increase in the flow rate, the amount of permeate flux has been prevented from forming a thin boundary layer on the membrane surface due to

disturbance and turbulence on the membrane surface, and as a result, the permeate flux has increased. The investigation of the combined effect of flow speed and pressure also showed that high speed and pressure, by increasing the turbidity on the membrane surface and preventing the formation of cake, played an important role in increasing the permeate flux (Figure 3). On the other hand, with the increase in flow rate and pressure, the time to reach equilibrium conditions has increased, which

15- Driving force

shows that the role of these two factors is very important in preventing membrane clogging.

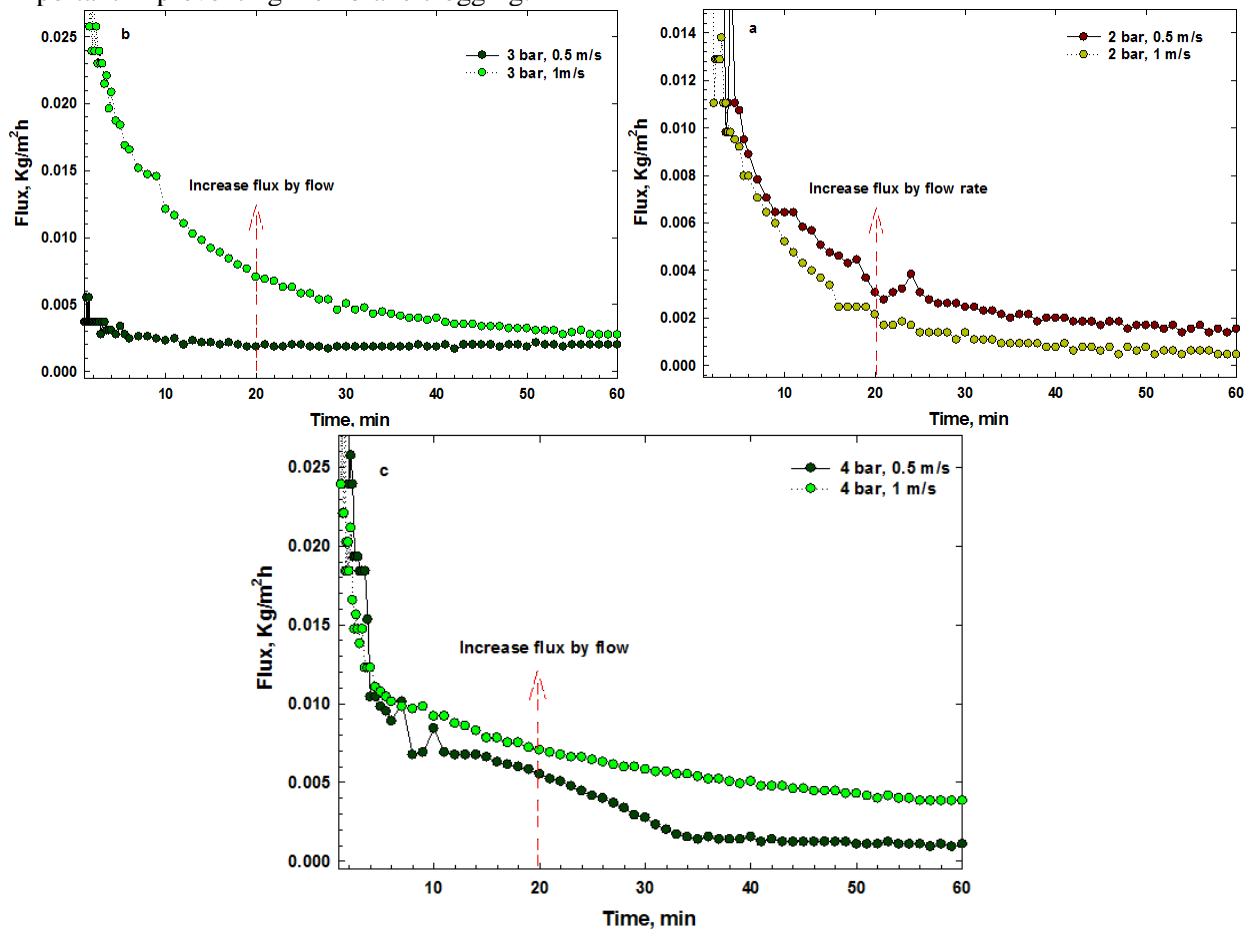

Figure 3 the effect of flow rate on permeate flux through degumming of canola oil micella (20:80)

3-3- The neutralization process of canola millet 20:80

In this section, the effect of pressure, flow rate and temperature on the permeate flux of canola oil (20:80) in the neutralization stage was investigated (Figure 4). Similar to the process of degumming, here too, after a period of time, the permeate flux decreased and reached a steady state, and with the increase in pressure, the permeate flux increased, but the combined effect of high flow rate and pressure on the flux was not noticeable. Farsi and Dahabi¹⁶ [19] have also reported the increase in flux with the increase in pressure during the filtration of textile factory effluent. The results showed that at a temperature of 40 degrees Celsius it is higher than the flux at temperatures of 30 and 50 degrees Celsius and this difference is more evident in the pressure of 3 times. With the increase in temperature, the viscosity of the oil has decreased and as a result,

the permeate flux has increased due to the increase in the hydraulic permeability of the membrane and as a result, the possibility of pore blockage due to sediment has decreased, but with an excessive increase in temperature and the formation of foam in the oil, it causes disruption in the flow. Its permeability and flux reduction were consistent with Darnoko's findings¹⁷ and colleagues [20]. At low speed and the formation of a concentration polarization layer on the surface of the membrane, applying more pressure on the cake has a significant effect on increasing the permeate flux; But by increasing the speed and removing the concentration polarization layer of the membrane, increasing the pressure has less effect on increasing the permeate flux. Alisio et al. [21] also reported that in a constant lateral pressure difference, increasing the process temperature increases the permeate flux, which is caused by the decrease in viscosity and the increase in the molecular diffusion coefficient of permeate [22].

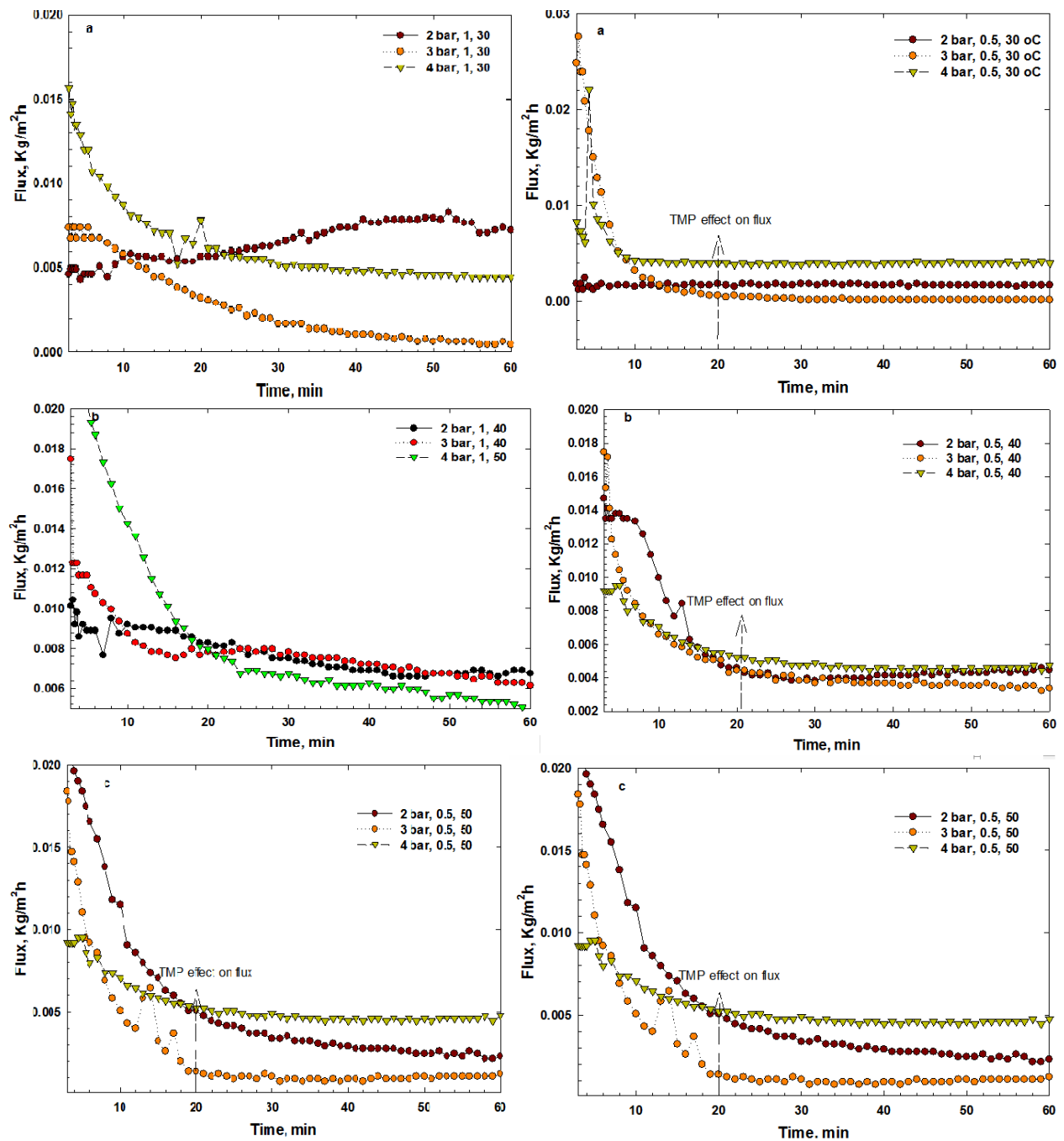

Figure 4 the effect of pressure and flow rate on neutralization of canola oil micella (20:80) at 30 °C (a), 40 °C (b) and 50 °C

4-3- The combined effect of temperature and pressure on the amount of seepage flux in the equilibrium conditions of canola millet 20:80

Figure (5) shows the combined effect of temperature and pressure on the amount of permeate flux in equilibrium conditions. As can be seen, although the permeation flux has increased with the increase in temperature and the decrease in the viscosity of misela from 30 to

40 degrees Celsius, but a further increase in temperature, especially at pressures above 3 and 4 bar, has the opposite result and the permeation flux has decreased. Therefore, a temperature of 40 degrees Celsius and a pressure of 4 bar have led to the maximum permeate flux, and by examining the effect of the flow rate of 0.5 and 1 in Figure 5-4, the most suitable operating conditions are as follows: temperature 40 degrees Celsius, pressure 4 load and flow speed of 1 m/s.

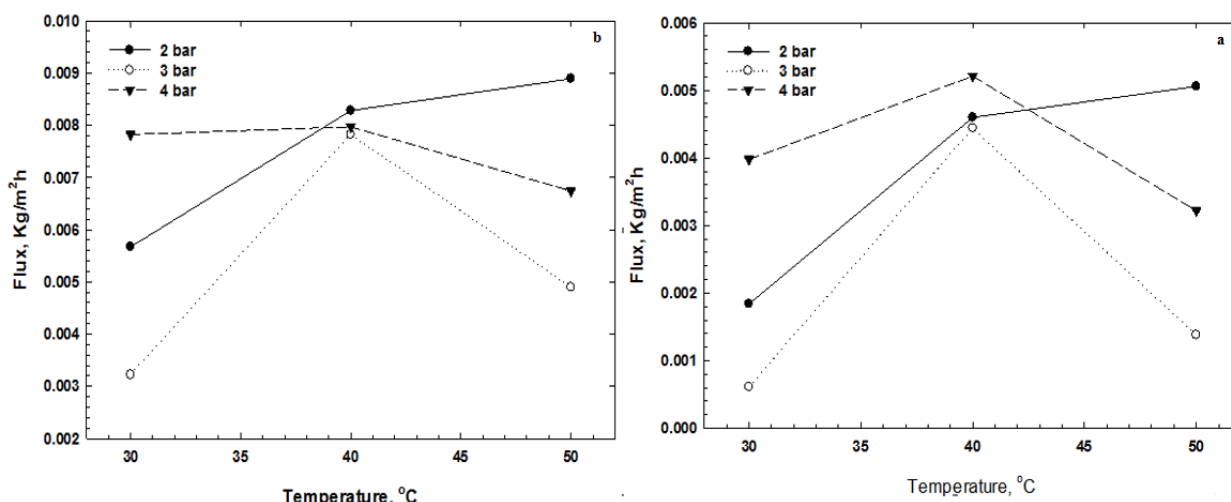

Figure 5 the combined effect of temperature and pressure on the permeate flux of canola oil micella (20:80) at equilibrium conditions (a = flow rate 0.5 m/s and b = flow rate 1.0 m/s)

5-3- Investigating the mechanism of membrane clogging for canola misela 20:80

The investigation of membrane clogging in the two stages of degumming and neutralization of canola oil misela showed that the dominant clogging mechanism in the degumming stage is cake and standard and in the neutralization stage it is cake type (Table 1). Amin¹⁸ et al. [23] and Hefidi et al. [5] also reached similar results. Some researchers have stated that the absorption

or accumulation of fatty acids in membrane pores reduces their size, but does not block them. On the other hand, some others have reported that the absorption of fatty acid to the pore wall of the membrane reduces the radius of the small pores. Therefore, absorption is limited to monolayers of fatty acids in the pores of the membrane. As more food passes through the membrane, the fatty acids inside the pores increase, and with their accumulation, single-layer absorption turns into multilayer absorption, which causes a greater drop in the relative flux in the membrane.

Table 1 Predominant folding mechanism of degumming and neutralization stages for canola oil micella (20:80)

raw	Stage of the process	P(bar)	V(m/s)	T(C ⁰)	R			T(C ⁰)	Type of folding
					Ln t _{0.5} v	t/v _{0.5} t	t/v _{0.5} v		
1	Degumming	2	0.5	-	0.9709	<u>0.9853</u>	0.9056	-	standard
2			1.0	-	0.9892	<u>0.9970</u>	0.7559	-	standard
3		3	0.5	-	0.7538	0.7459	<u>0.7933</u>	-	cake layer
4			1.0	-	0.9354	<u>0.9911</u>	0.9187	-	standard
5		4	0.5	-	0.9920	<u>0.9958</u>	0.7848	-	standard
6			1.0	-	0.8905	0.9480	<u>0.9957</u>	-	cake layer
7	Neutralization	0.5	30		<u>0.7111</u>	0.3377	0.3494	30	intermediate
8			40		0.8081	0.8914	<u>0.9175</u>	40	cake layer
9			50		0.9443	<u>0.9837</u>	0.9269	50	standard
10		2	30		0.0738	<u>0.6812</u>	0.0049	30	standard
11			1.0	40		0.7466	0.9129	<u>0.9391</u>	40
12		3	50		<u>0.7271</u>	0.4425	0.4505	50	intermediate
13			30		0.9141	<u>0.9997</u>	0.04465	30	standard
14			0.5	40		0.8758	0.9392	<u>0.9947</u>	40
15		1.0	50		0.9730	<u>0.9779</u>	0.8575	50	standard
16	30			0.9377	<u>0.9924</u>	0.6850	30	standard	

17		40	0.7805	0.8715	<u>0.9273</u>	40
18		50	0.8025	0.8540	<u>0.9095</u>	50
19	0.5	30	0.8008	0.8389	<u>0.8962</u>	30
20		40	0.7675	0.7838	<u>0.8359</u>	40
21	1.0	50	0.9152	0.9701	<u>0.9937</u>	50
22		30	0.8404	0.8933	<u>0.9738</u>	30
23	4	40	0.9010	0.9617	<u>0.9906</u>	40
24		50	0.8969	0.9562	<u>0.9958</u>	50

cake layer

6-3- The effect of pressure on the seepage flux of canola mille 30:70 in the gumming stage

The effect of pressure on the gumming process of canola oil (30:70) at constant speeds of 0.5 and 1 m/s is presented in Figure (6). Similar to 80:20 sample, the results revealed that at low speed, the

difference between the permeation flux at different pressures is not significant, but with the increase in pressure, the permeation flux also increased, and this increase was greater at high speed, and there was a significant difference in the amount of flux. Permeation was at high speed with increasing pressure.

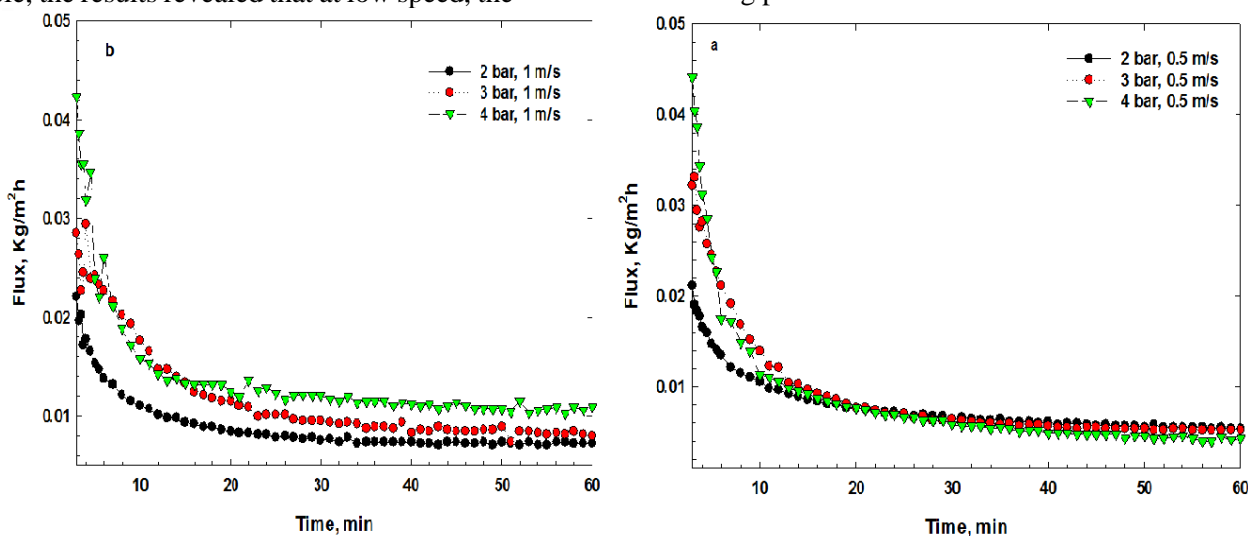
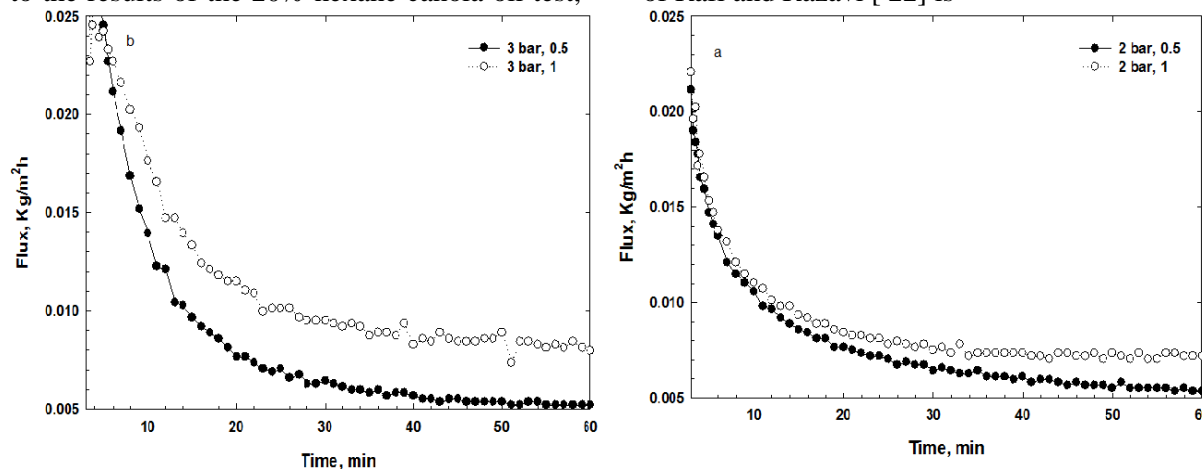

Figure 6 the effect of pressure on permeate flux through degumming process of canola oil micella (30:70)

7-3- The effect of flow speed on the seepage flux of canola mille 30:70 in the gumming stage

According to Figure (7), it was found that similar to the results of the 20% hexane canola oil test,

with the increase in speed, the amount of permeate flux also increased and also the amount of flux difference increased with the increase of flow pressure, which is in line with the findings of Rafi and Razavi [22] is



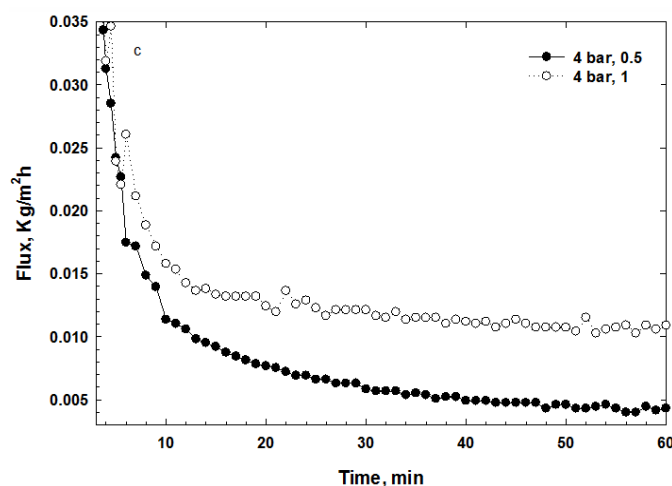
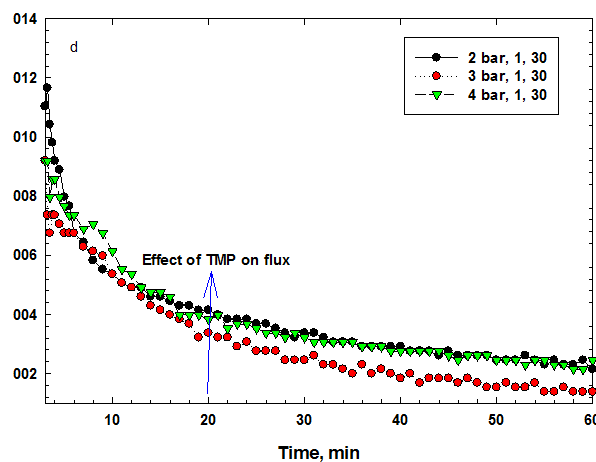
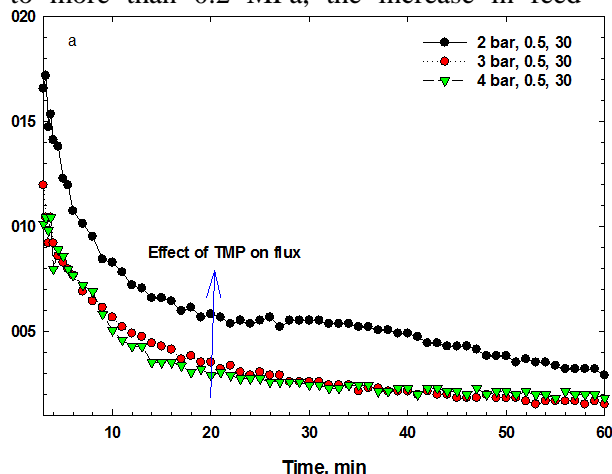

Figure 7 the effect of flow rate on permeate flux through degumming of canola oil micella (30:70)

8-3- The process of neutralization of canola oil 30:70

The results related to the effect of pressure, speed and temperature on the permeate flux of 70:30 Mislai are shown in Figure (8). According to the results, in both flow velocities, increasing the pressure did not have a positive effect on increasing the permeate flux and even caused a decrease in the permeate flux, which is in line with the results of Zhu¹⁹ and colleagues [24]; They reported that the permeate flux increases with increasing pressure up to 0.2 MPa and then decreases. According to their opinion, the increase in pressure during the filtration process causes the membrane to compress through the food, the thickness of the membrane is reduced to a small amount, and as a result, the resistance to the food increases. By increasing the pressure to more than 0.2 MPa, the increase in feed

resistance overcomes the increase in permeate flux, and the flux decreases. Also, the results showed that with the increase in temperature and the increase in the flow rate, the amount of seepage flux increases, and these results are in agreement with Rothenbach's findings.²⁰ [25] was consistent. In general, it can be concluded that increasing the temperature up to about 40 degrees had a relatively positive effect on the increase of percolation flux. In other words, at a temperature of 40 degrees Celsius, we had an increase in the permeation flux at first, then a decreasing trend, and finally the permeation flux reached a stable state. The decrease in the feed viscosity due to the increase in temperature affects the behavior of the sediment phase on the membranes and reduces the possibility of blocking the membrane pores by particles [26].



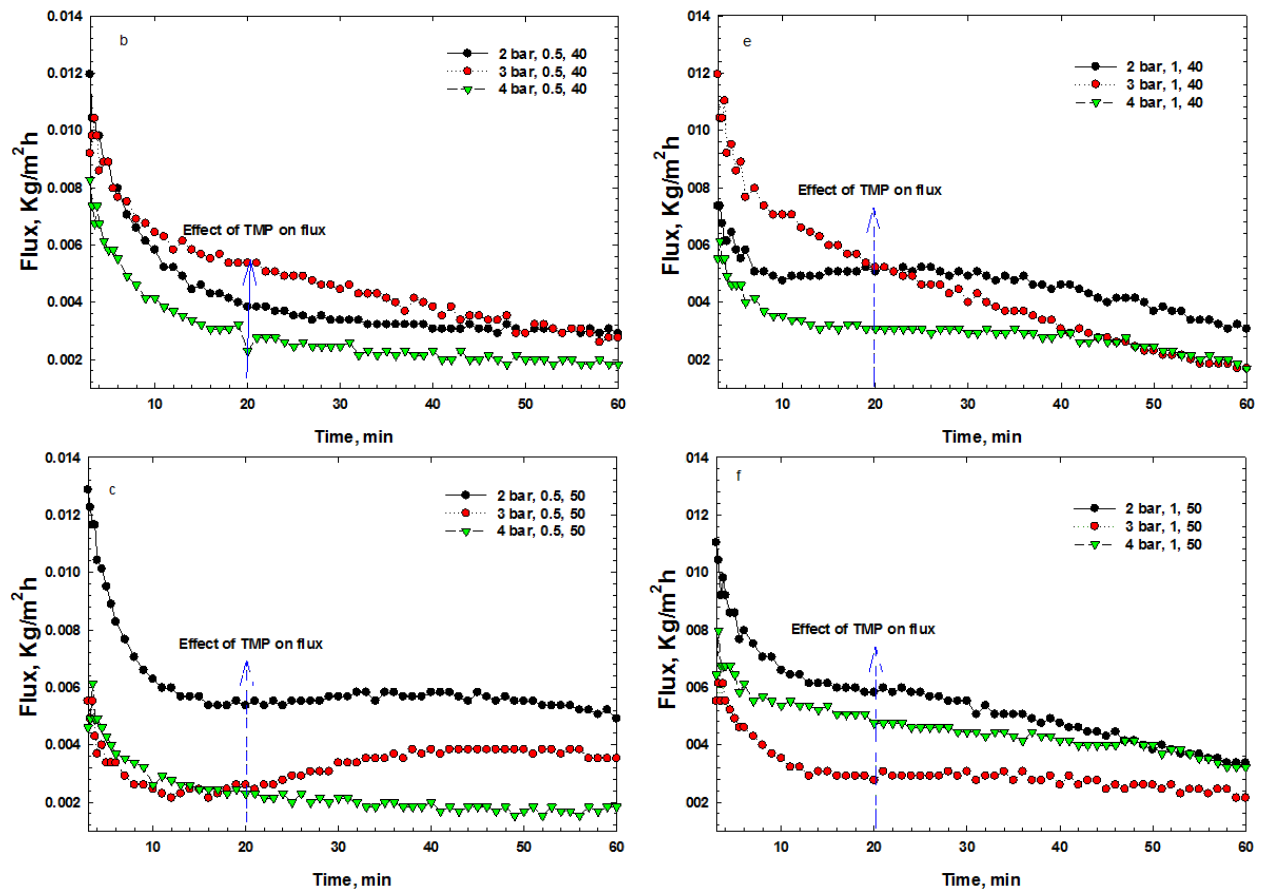
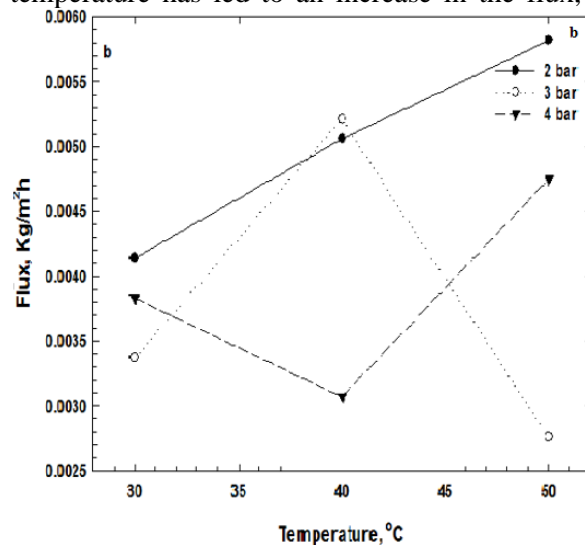

Figure 8 the effect of pressure and flow rate on neutralization of canola oil micella (30:70) at 30 °C (a), 40 °C (b) and 50 °C

9-3- The combined effect of temperature and pressure on the amount of seepage flux in equilibrium conditions of canola millet 30:70

It can be seen in Figure (9) that unlike the case of 20% oil, here at 2 bar pressure, the permeate flux was higher than at 3 and 4 bar pressures, in other words, the pressure did not lead to an increase in flux. On the other hand, the increase in temperature has led to an increase in the flux,



except for the pressure of 4 bar, and the effect of the flow speed on the permeate flux was not noticeable. Therefore, a temperature of 50 degrees Celsius and a pressure of 2 bar have led to the maximum permeate flux, and by examining the effect of the flow rate of 0.5 and 1 in Figure (9), the most suitable operating conditions are as follows: temperature 50 degrees Celsius, pressure 2 load and flow speed of 1 m/s.

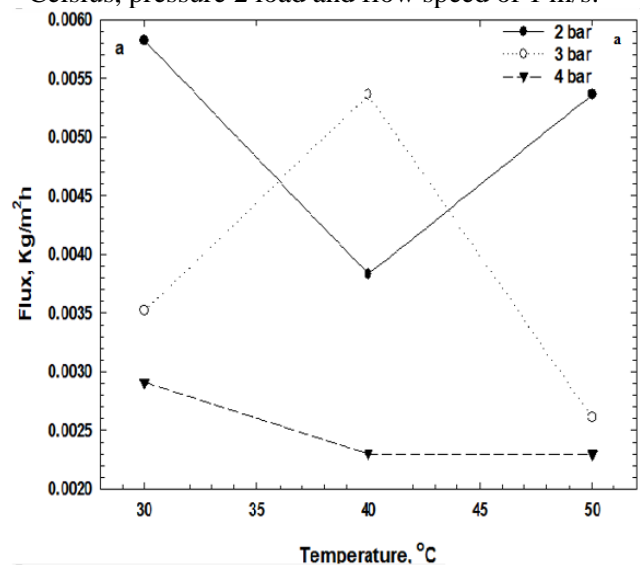

Figure 9 the combined effect of temperature and pressure on the permeat flux of canola oil micella (30:70) at equilibrium conditions (a = flow rate 0.5 m/s and b = flow rate 1.0 m/s)

10-3- Investigating the mechanism of the clogging of the membrane of canola 30:70

According to table (2), it can be concluded that both in the gum removal and neutralization stages, we mostly saw clogging in the form of cake formation. Since it is not possible to stick or absorb all the fatty acids with low molecular weight to the membrane pores, the rest of the fatty acids form a cake layer that causes

concentration polarization. According to table (2) and as mentioned in the dominant mechanism section, in the gumming phase, the blockage was cake-type and with the passage of time, it approached the middle blockage. Also, in the neutralization stage, the clogging index was similar to the clogging index of 20% canola oil misela, and they were mostly in the range of cake-type clogging.

Table 2 Predominant folding mechanism of degumming and neutralization stages for canola oil micella (30:70)

raw	Stage of the process	P(bar)	V(m/s)	T(C ⁰)	R			Type of folding		
					$\ln t \text{ } \Delta v$	$t/v \text{ } \Delta t$	$t/v \text{ } \Delta v$			
1	Degumming	2	0.5	-	0.9087	0.9528	<u>0.9948</u>	cake layer		
2			1.0	-	0.8906	0.9366	<u>0.9860</u>			
3		3	0.5	-	<u>0.9806</u>	0.9452	0.9726	intermediate		
4			1.0	-	0.8919	0.9495	<u>0.9975</u>	cake layer		
5		4	0.5	-	0.9656	<u>0.9863</u>	0.9452	standard		
6			1.0	-	0.9093	0.9488	<u>0.9879</u>			
7	Neutralization	2	0.5	30	0.9140	0.9598	<u>0.9938</u>	cake layer		
8				40	0.8997	0.9535	<u>0.9973</u>			
9				50	0.8477	0.8948	<u>0.9364</u>			
10		3	0.5	30	0.9230	0.9657	<u>0.9917</u>			
11				40	0.8282	0.8507	<u>0.8967</u>			
12				50	0.8538	0.9073	<u>0.9634</u>			
13		4	0.5	30	0.9459	<u>0.9801</u>	0.9766	standard		
14				40	0.8758	0.9304	<u>0.9872</u>	cake layer		
15				50	0.7921	<u>0.7986</u>	0.7840	standard		
16		2	1.0	30	0.9007	0.9776	<u>0.9841</u>			
17				40	0.9111	0.9626	<u>0.9952</u>			
18				50	0.8439	0.9206	<u>0.9618</u>			
19	30			0.9166	0.9755	<u>0.9897</u>				
20	3			1.0	40	0.9239	0.9622		<u>0.9925</u>	cake layer
21					50	0.9205	0.9566		<u>0.9864</u>	
22	4	1.0	30	0.8973	0.9518	<u>0.9987</u>				
23			40	0.8560	0.8994	<u>0.9548</u>				
24			50	0.8293	0.8598	<u>0.9125</u>				

3-11- Results of physicochemical parameters of 20% and 30% canola oil during classical purification and membrane purification during passage From the first stage and the second stage of membrane filtration

Table 3 comparing physicochemical parameters of classic refining and membrane filtration process for 20% and 30% canola oil

The results of the physicochemical parameters of canola oil and the comparison of the membrane method and the classical method are as described in Table (3).

Type of oil	Refining stage	Acidity (%)	Peroxide (meq/kg)	Phosphorus (mg/kg)	Phosphatide (%)	Red colour index (R)	Yellow colour index (Y)
Classic refined oil	Crude oil	1.4 ^c	0.86 ^d	294.6 ^d	0.88 ^d	5.1 ^b	70 ^a
	degumming	1.6 ^b	0.70 ^e	329.6 ^a	0.98 ^a	5.4 ^a	70 ^a
	neutralization	0.07 ^d	1.42 ^a	0.066 ^e	0.00019 ^e	3.8 ^c	70 ^a
	Bleaching	0.066 ^{ed}	0/00 ^h	0.033 ^e	0.00009 ^e	2.0 ^h	34 ^b
Canola (20:80)	Filtration I	1.83 ^a	0.63 ^f	317.6 ^b	0.95 ^b	3.3 ^d	70 ^a
	Filtration II	0.05 ^e	1.11 ^b	0.032 ^e	0.00009 ^e	2.8 ^f	70 ^a
Canola (30:70)	Filtration I	1.83 ^a	0.54 ^g	314.3 ^c	0.094 ^c	2.9 ^e	70 ^a
	Filtration II	0.05 ^e	0.96 ^c	0.031 ^e	0.00009 ^e	2.6 ^g	70 ^a

The results are reported as mean±standard deviation. Dissimilar Latin letters indicate significance at the probability level less than 1%

1-11-3- Measurement of acidity

According to the results in table (3), the amount of acidity in the membrane method has been significantly reduced in the second filtration in both canola oil by 20 and 30% compared to neutralized and even bleached oil ($p < 0.01$). These results show that membrane filtration has a greater ability to reduce the amount of free fatty acids compared to the classical purification method. The highest amount of acidity in both types of canola oil, 20 and 30%, occurred in the first filtration stage, which could be due to the acidic conditions created by phosphoric acid added in the gumming stage. These results did not match the findings of Azmi et al. [27], Hu et al. [8], but they were consistent with the results of Cao et al. [9] and Rafee et al. [28].

2-11-3- Measurement of peroxide index

The comparison of the peroxide value of the two stages of the membrane process with the oil refined by the classical method (Table 3) shows that the peroxide value of the oil due to the classical purification method reached zero, but the membrane method was able to reduce it to a maximum of 0.9 milliequivalent gram. reduce it per kilogram, which of course is less than the maximum acceptable value (10 milliequivalent grams per kilogram) [29]. The removal of natural antioxidants such as phenolic compounds, and proximity to air during ultrafiltration

may be among the factors that increase peroxide value in membrane filtration. These results are in line with the findings of Hefidi et al. [5] and Butino²¹ and colleagues [30].

3-11-3- Phosphorus and phosphatides

As can be seen in table (3), the amount of phosphorus (329.6 mg/kg) is higher in the oil extracted by the classical method than in the crude oil (294.6 mg/kg) because in this The gumming method is done by acid method and the phospholipids which are non-hydrophilic are separated by adding phosphoric acid to the oil in this step and with this method, which increases the phosphorus content in this step, but in the step Phosphorus neutralization is removed and its amount is reduced. Also, as can be seen from the results in Table (3), both classical and membrane purification methods are able to reduce the phosphorus and phospholipid content of canola oil by 99.9%; But there is no significant difference between the phosphorus and phospholipid content of the oil refined by the classical method and the oil refined using membrane filtration ($P < 0.01$); Therefore, it was determined that the membrane filtration process of raw canola oil can reduce the amount of phospholipids to an acceptable level; These results are in line with the findings of Abdullah et al. [6], Arianti et al. [31] and also Ismail²² and colleagues [32].

4-11-3- Colorimetry

According to the results listed in table (3), the yellow color in classical purification and in the decolorization stage is significantly lower than the membrane filtration method ($p < 0.01$), but in other samples, there is a significant difference between the yellow color. There is none ($p < 0.01$), which shows that the membrane filtration method has a weaker performance in reducing the yellow color than the classical purification method; These results were consistent with the findings of Subramanian et al. [16]; However, these pigments were largely sequestered by the membrane; In explaining this phenomenon, they stated that the non-passage of these colored compounds was due to its trapping in the phospholipids present in the crude oil. Regarding the red color, the results showed that the chemical purification method was able to reduce the redness index by 60%, but this number is 49% and 45% for 20% and 30% filtered canola oil, respectively, which is a significant difference. It is considered significant ($p < 0.01$) and shows the higher efficiency of the classical purification method than the membrane filtration method in reducing redness. These findings were in accordance with the results of Moore and Gogat [7] and Rafe et al. [15]. With these interpretations, it should be noted that the oils refined by the membrane method are close to the oil decolorized by the classical method in terms

5- Resources

- [1] Tomaino, A., Cimino, F., Zimbalatti, V., Come. (2005). Influence of Heating on antioxidant activity and the chemical composition of some spice essential oil, *Food Chemistry*, 89(4):549-554.
- [2] Khattab, R., Rempel, C., Suh, M., & Thiyam, U. (2012). Quality of canola oil obtained by conventional and supercritical fluid extraction, 3(12): 966-976.
- [3] Niazmand, R., Farhoush, R., Razavi, S.M.A., Mousavi, S.M. (2013). Investigating the effect of membrane filtration process on

of the redness index, which can validate the ability to use these systems instead of conventional chemical purification methods.

4- Conclusion

The current research investigated and compared the efficiency of two methods "membrane filtration" and "classical purification" in gum removal, neutralization and decolorization of crude canola oil and the optimal conditions of membrane performance (temperature, pressure and flow rate) were determined; Also, the results of the physicochemical tests revealed that there was a significant difference between the two methods and that the membrane filtration method performed better than the classical method; But in reducing the peroxide index, the classic method performed significantly better; In the gumming process, there was no significant difference, and the amount of phosphorus and phosphatide residue was the same in both methods, and finally, the results of the colorimetric test also showed that there was no significant difference between the yellowness index, but in the classical method, there was little. was less; Regarding the redness index, there was no significant difference between the two methods, but the classic method performed slightly better. Therefore, by using membrane processes in the oil refining industry, it is possible to achieve the desired results by using lower temperatures, removing dye-bearing soil, and consuming less energy (compared to classical semi-processes).

oxidation parameters of canola oil. *Quarterly Journal of Food Sciences and Industries*. 40(10): 81-91.

[4] Salehi, F.D., Raxavi, S.M.A. (2010). Solvent recovery from rapeseed oil-hexane misela using nanofiltration membrane process. *Electronic magazine of food processing and preservation*. 2(4): 107-121.

[5] Hafidi, A., Pioch, D., & Ajana, H. (2005). Membrane-based simultaneous degumming and deacidification of vegetable oils. *Innovative Food Science and Emerging Technologies* 6: 203-212.

- [6] Abdellah, M. H., Scholes, C. A., Liu, L., & Kentish, S. E. (2019). Efficient degumming of crude canola oil using ultrafiltration membranes and bio-derived solvents. *Innovative Food Science & Emerging Technologies*, 59: 102-274.
- [7] More, N. S., & Gogate, P. R. (2018). Intensified degumming of crude soybean oil using cavitation reactors. *Journal of Food Engineering*, 218: 33–43.
- [8] Hou, Z; Cao, X; Cao, L; Ling, G; Yu, Z and Pang, M (2020). The removal of phospholipid from crude rapeseed oil by enzyme-membrane binding. *J. Food Eng.* 280: 1-16
- [9] Cao, T.N, Bui, X.T., Le, L.T, Dang, B., Tran D.P.H., Vo, T.K.Q., Tran, H.T., et al. (2022). An overview of deploying membrane bioreactors in saline wastewater treatment from perspectives of microbial and treatment performance. *Bioresource Technology*. 363: 127-146.
- [10] Hermia, J (1982). Constant pressure blocking filtration law application to powder-law non-newtonian fluid. *Tran's inst Chem eng*, 60: 183-187.
- [11] American Oil Chemists' Society. (2009). *AOCS Official Method Ca 12-55: Phosphorus*, 2 pages.
- [12] Isiri, 4179. (2017). Vegetable and animal oils and fats - measurement of peroxide amount by iodometric method - determination of end point by visual method, National Organization of Standards of Iran.
- [13] Isiri, 4178. (2021). Vegetable and animal oils and fats - Measurement of acid number and acidity, National Organization of Standards of Iran.
- [14] American Oil Chemists' Society. (2009). *AOCS Cc 13e_02: colour*, 2 pages.
- [15] Rafe, A., Razavi, S. M. A., & Khodaparast, M. H. (2012). Refining of crude canola oil using PSA ultrafiltration membrane. *International Journal of Food Engineering*, 8(2): 1-23.
- [16] Subramanian, R., Raghavarao, K., Nabetani, H., Nakajima, M., Kimura, T., & Maekawa, T. (2001). Differential permeation of oil constituents in nonporous dense polymeric membranes. *Journal of Membrane Science*, 187: 57–69.
- [17] Tres, M. V., Mohr, S., Corazza, M. L., Luccio, M. D., & Oliveira, J. V. (2009). Separation of n-butane from soybean oil mixtures using membrane processes. *Journal of Membrane Science* 333: 141-146.
- [18] Pagliero, C., Mattea, M., Ochoa, N., Marchese, J. (2007). Fouling of polymeric membranes during degumming of crude sunflower and soybean oil. *Journal of Food Engineering* 78: 194–197.
- [19] Fersi, C., Dhahbi, M. (2008). Treatment of textile plant effluent by ultrafiltration and/or nanofiltration for water reuse. *Desalination*, 222 (1-3): 263-271.
- [20] from Darno, D. (2006). Carotenoids from red palm methyl esters by nanofiltration. *Journal of the American Oil Chemist's Society*, 83(4): 365-370
- [21] Alicieo, T.V.R., Mendes, E.S., Pereira, N.C., Lima, O.C.M. (2002). Membrane ultrafiltration of crude soybean oil. *Desalination*, 148 (1-3): 99-102.
- [22] Rafe, A. & Razavi, S. M. A., (2009). Water and hexane permeate flux through UF polysulfone amide membrane. *Desalination*, 236: 39-45.
- [23] Amin, I. N. H. M., Mohammad, A. W., Markom, M., Peng, L. C., & Hilal, N. (2010). Flux decline study during ultrafiltration of glycerin-rich fatty acid solutions. *Journal of Membrane Science* 351: 75-86.
- [24] Zhu, X., Dudchenko, Gu, A., Jassby X. D. (2017). Surfactant-stabilized oil separation from water using ultrafiltration and nanofiltration, *J. Membr. Sci.* 529: 159–169.
- [25] Rautenbach, R. (1989). *Membrane processes*. Chichester, New York : Wiley.
- [26] Hua, B., & Scott, K. (2008). Microfiltration of water in oil emulsions and evaluation of fouling mechanism. *Chemical Engineering Journal* 136: 210-220.
- [27] Azmi, A.R., Gog, P., Ismail, A.F., Lau, W.J., Othman, N.H. Noor, A.M. Yusoff, M.S.A. (2015). Deacidification of crude palm oil

using PVA-crosslinked PVDF membrane, *Journal of Food Engineering*, 166: 165-173

[28] Niazmand, R; Mohammad, S; Razavi, A., and Farhoosh, R (2015). Colloid-enhanced ultrafiltration of canola oil: Effect of process conditions and MWCO on flux, fouling and rejections. *J. Food Process. Preserv.* 39: 292-300.

[29] FAO. (1999). Codex Standard for Edible Fats and Oils, CODEX STAN 19-1981, Rev.2.

[30] Bottino, A., Capannelli, G., Comite, A., Ferrari, F., Marotta, F., Mattei, A., & Turchini, A. (2004). Application of membrane processes for the filtration of extra virgin olive oil. *Journal of Food Engineering*, 65: 303-309.

[31] Aryanti, N., Wardhani, D.H., Nafiunisa A. (2018). Ultrafiltration membrane for degumming of crude palm oil-isopropanol mixture *Chem. Biochem. Eng. Q.*, 32 (3): 325-334.

[32] Ismail, D.N.F.A., Ghazali, N. (2018). Separation of fatty acids from palm oil using organic solvent nanofiltration. *Malaysian Journal of Analytical Science* 22(3):561-569.



امکان سنجی صمغ گیری و خنثی سازی روغن خام کانولا با استفاده از غشای پلی وینیلیدین فلوئوراید

مریم رشیدیان^۱، مریم قراچورلو^۲، منوچهر بهمنی^۳، مهرداد قوامی^۴، حسین میرسعید قاضی^۵

۱- دانش آموخته دکترای علوم و صنایع غذایی، واحد علوم و تحقیقات، دانشگاه آزاد اسلامی، تهران، ایران

۲- استاد گروه علوم و صنایع غذایی، واحد علوم و تحقیقات، دانشگاه آزاد اسلامی، تهران، ایران

۳- دانشیار گروه شیمی، واحد تهران شمال، دانشگاه آزاد اسلامی، تهران، ایران

۴- استاد گروه علوم و صنایع غذایی، واحد علوم و تحقیقات، دانشگاه آزاد اسلامی، تهران، ایران

۵- دانشیار گروه فناوری صنایع غذایی، دانشکده فناوری کشاورزی، دانشکده‌گان کشاورزی و منابع طبیعی، دانشگاه تهران، تهران، ایران

اطلاعات مقاله	چکیده
تاریخ های مقاله :	در این پژوهش امکان‌سنجی صمغ‌گیری و خنثی‌سازی روغن خام کانولا با استفاده از فرایند غشایی بررسی شده است. میسلای روغن خام کانولا با استفاده از حلال هگزان به نسبت‌های ۲۰:۸۰ و ۳۰:۷۰ تهیه و جهت صمغ‌گیری و پس از افزودن ۰/۳٪ اسیدفسفریک ۰/۸۵٪ تحت سطوح فشار ۲، ۳ و ۴ بار و سرعت جریان در ۰/۵ و ۱/۰ m/s از غشا عبور داده شد؛ در مرحله خنثی‌سازی نیز پس از افزودن محلول آبی سود NaOH در دو غلظت ۱۰٪ و ۳۰٪ تحت شرایط قبل و همچنین سطوح دمایی ۳۰، ۴۰ و ۵۰ درجه سانتیگراد از غشا عبور داده شد. مطابق نتایج در میسلای ۲۰:۸۰، با گذشت زمان شار تراوه به تدریج کاهش یافته و پس از ۲۰ دقیقه به حالت پایا رسید؛ بررسی اثر توام دما و فشار بر میزان شار تراوه در مرحله خنثی‌سازی و در شرایط تعادلی آشکار ساخت که بیشترین شار مربوط به شرایط ۴۰°C ⁰ و ۴ bar و ۱/۰ m/s می‌باشد؛ همچنین در میسلای ۳۰:۷۰ نیز بیشترین شار مربوط به شرایط ۵۰°C ⁰ و ۲ bar و ۱/۰ m/s بود. نتایج آزمون‌های فیزیکوشیمیایی نیز آشکار ساخت که اختلاف معنی داری میان میزان فسفر و فسفاتیدها در هر دو روش فیلتراسیون غشایی و تصفیه سنتی مشاهده نشد (p<۰/۰۱)؛ اما کاهش اسیدیته در روش فیلتراسیون غشایی نسبت به روش تصفیه کلاسیک، به طرز معنی داری بیشتر بود (p<۰/۰۱). کاهش اندیس پراکسید نیز در روش تصفیه کلاسیک نسبت به روش فیلتراسیون غشایی، به طرز معنی داری بیشتر بود (p<۰/۰۱). از لحاظ رنگ نیز نتایج نشان داد که روش فیلتراسیون غشایی قادر به کاهش رنگ زرد در روغن خام نبود در حالی که روش تصفیه کلاسیک، به طرز معنی داری رنگ زرد را کاهش داد (p<۰/۰۱). شاخص رنگ قرمز در روش تصفیه کلاسیک نیز، کاهش معنی داری نسبت به روش غشایی داشت (p<۰/۰۱).
تاریخ دریافت: ۱۴۰۳/۲/۱۱	
تاریخ پذیرش: ۱۴۰۳/۴/۳۰	
کلمات کلیدی:	
روغن کانولا، غشاء، تصفیه، شار تراوه، فسفاتیدها، اسیدیته، رنگ	
DOI:10.22034/FSCT.21.156.167.	
*مسئول مکاتبات: M_Gharachorlo@srbiau.ac.ir	